



Dror Artzi

To Boldly Go Where We Have Never Gone Before



104 שנים לטיסתם ההיסטורית  
של האחים



Dror Artzi

## ***The Dawn of The Era of Powered Flight Wright Brothers Flyer – December 17 1903 At 10:35***

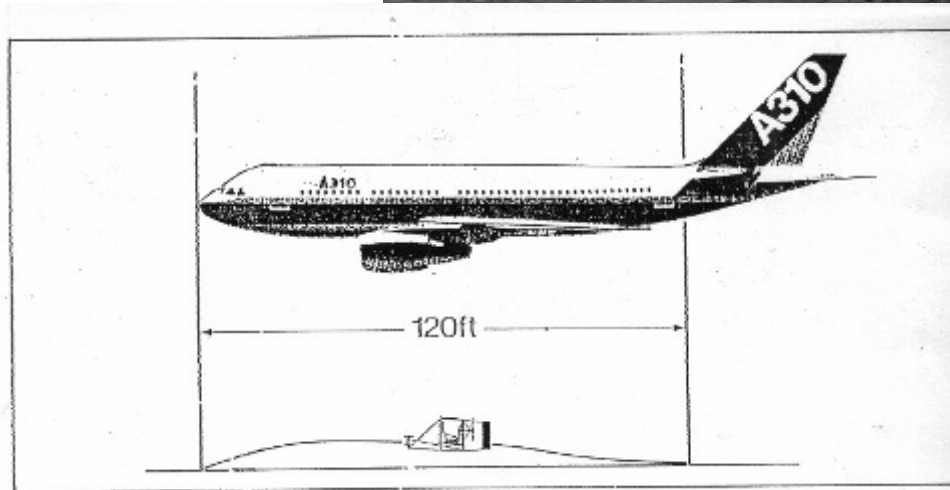
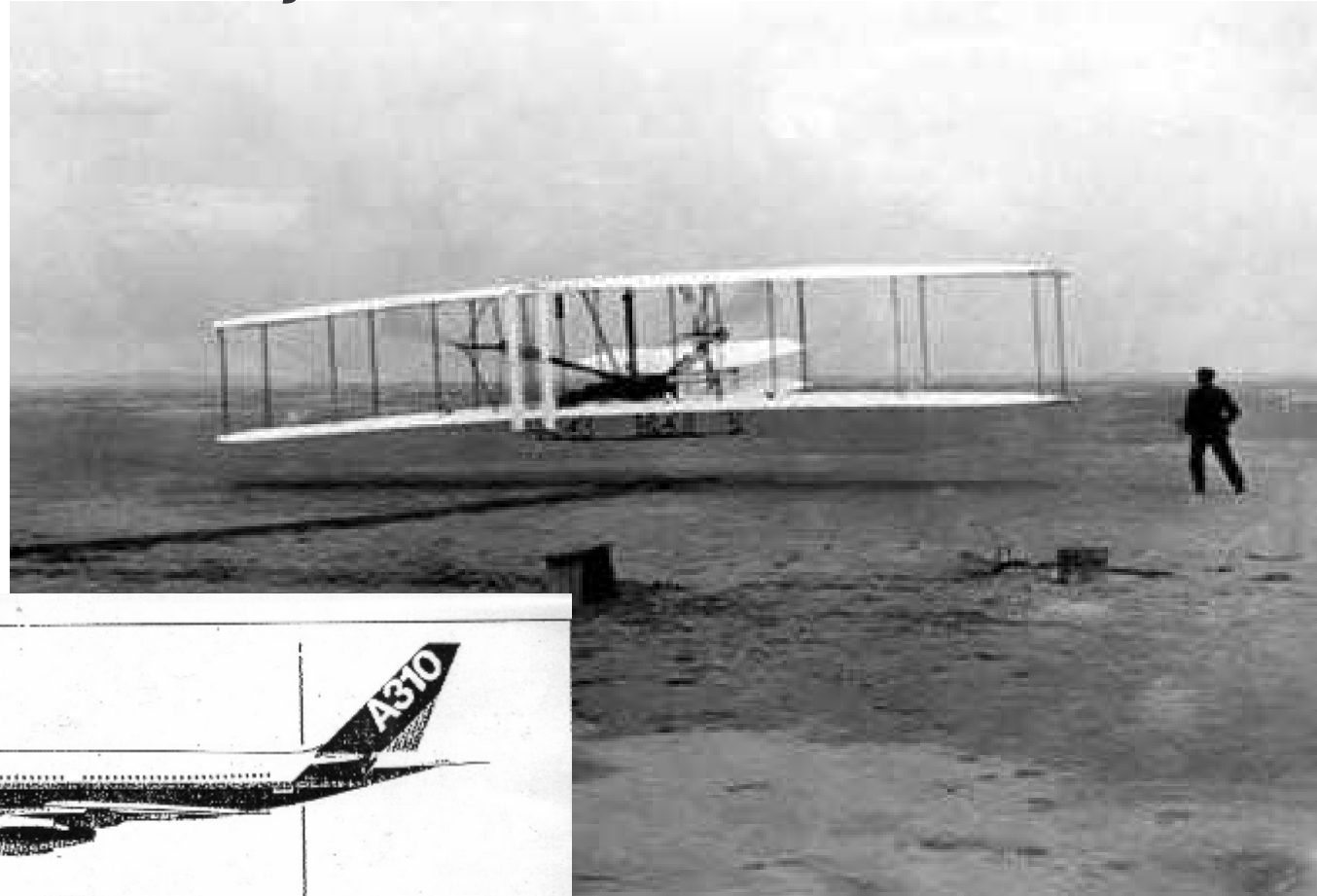



Dror Artzi

Wilbur and Orville in 1878, ages 12 and 8.



The brothers' interest in flying started in 1878 when their father, Milton, gave them a rubber-band-powered toy helicopter which 12-year-old Wilbur and eight-year-old Orville copied.





Dror Artzi

## 7 Hawthorn Street in Dayton





Dror Artzi

## תצפיות על מעוף ציפורים





Dror Artzi





Dror Artzi

## הפרחת עפיפונים





Dror Artzi

In 1893, the brothers opened the Wright Cycle Company in their hometown of Dayton, Ohio.

28 ; 23

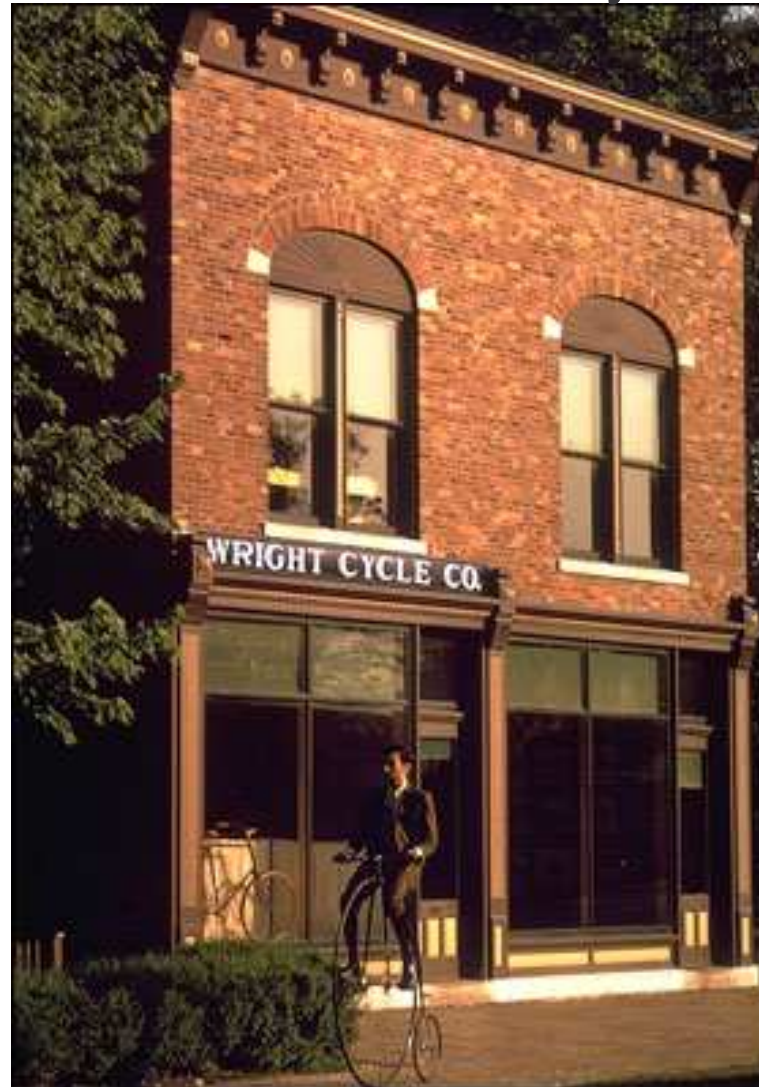



Dror Artzi

St. Clair model was built in 1898.  
Less expensive than the Van Cleve,  
the St. Clair sold for \$42.50.





The brothers decided to measure the lift and drag coefficients themselves.

They first built some small models of a wing and a flat plate and attached them to a bicycle wheel.

Here is the configuration that the wheel would assume as it was moved through the air.

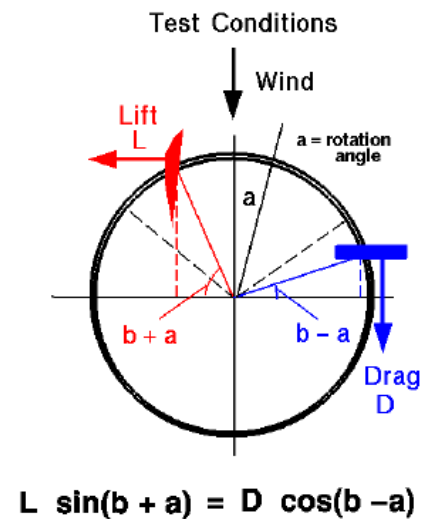
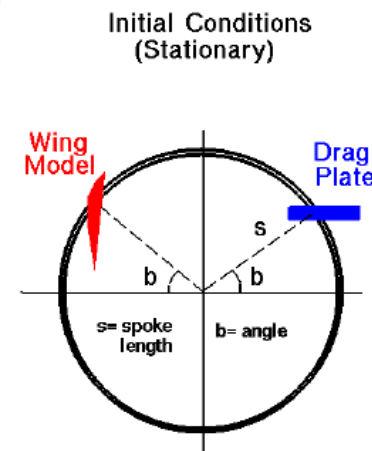

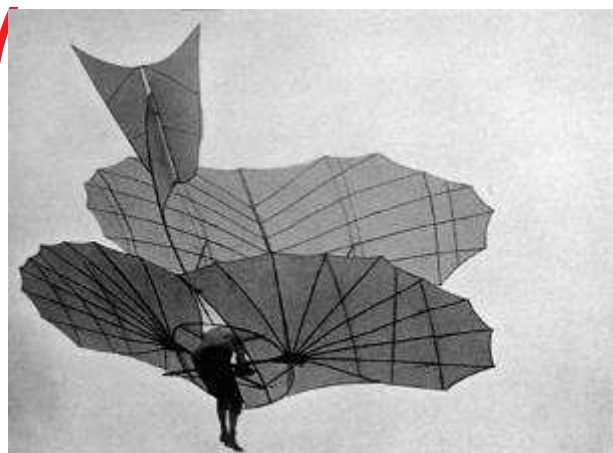

מותו של אוטו ליליינטל (OTTO LILIENTHAL)

בתאונה ב 1896

דחף את האחים לחקור יותר בנושא

האחים התפעלו מההישגים המרשימים שלו

דווקא על רקע העובדה שהוא צבר רק

5 שעות באוויר ב 2000 טיסות במהלך חמש

שנים

האחים הבינו שבעיית הטסת מכונה באוויר לא נפתרה עד עתה

כי בכל הנסיונות לא צברו מספיק זמן אמיתי באוויר

ולכן הבינו שעליהם לבנות מכונה שתעמוד ברוח של 18 קשרים

ולמצוא מקום בו קיימת רוח כזו כך שיוכלו להחזיק את המכונה

באוויר לפרקי זמן ארוכים ויוכלו לצבור הרבה יותר זמן האוויר

ולימוד רציף של התופעות



Dror Artzi



Wilbur Found The Wind-Swept Dunes of Kitty Hawk  
Perfect For Testing.



Dror Artzi

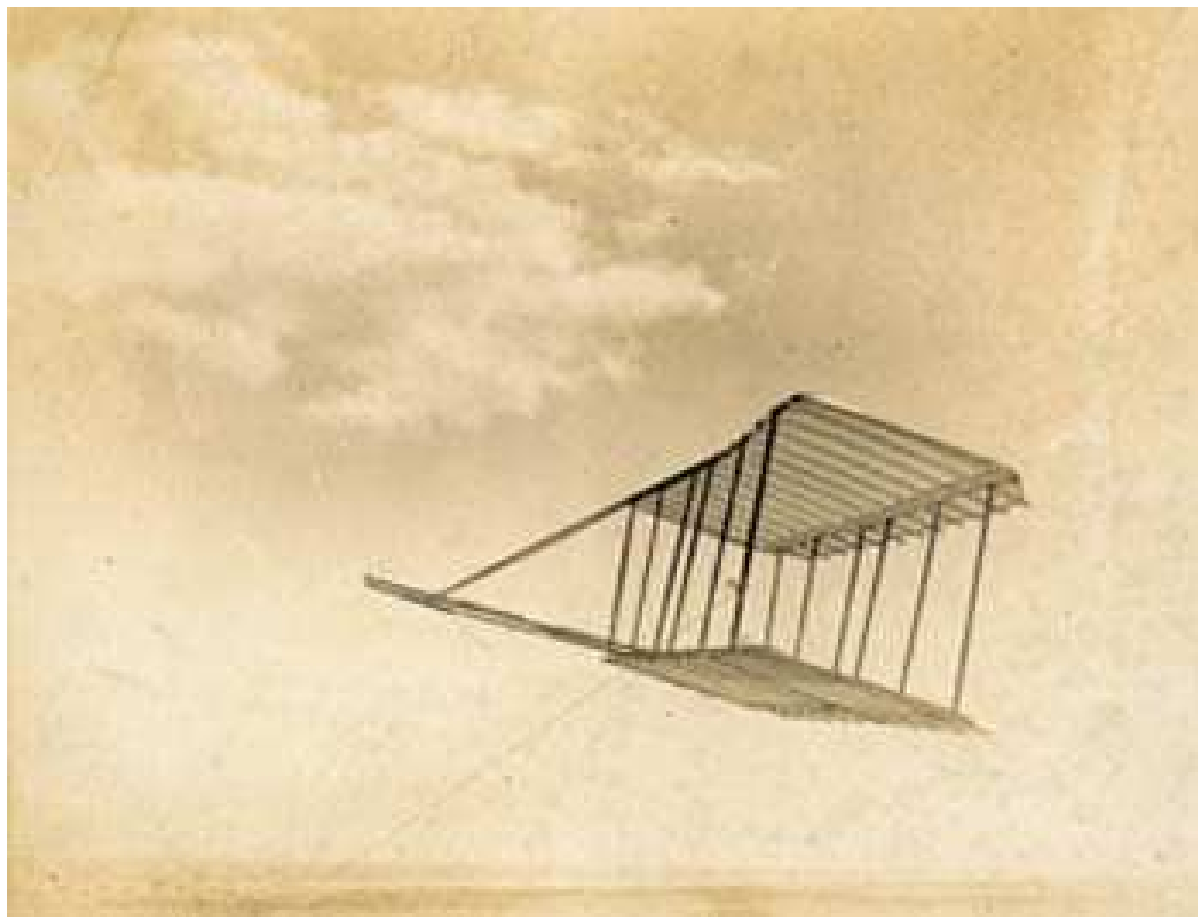

The glider was completed the first week in October 1900



Dror Artzi

*When the Wrights flew their gliders as kites, the rope described the hypotenuse of the lift-drag triangle.*

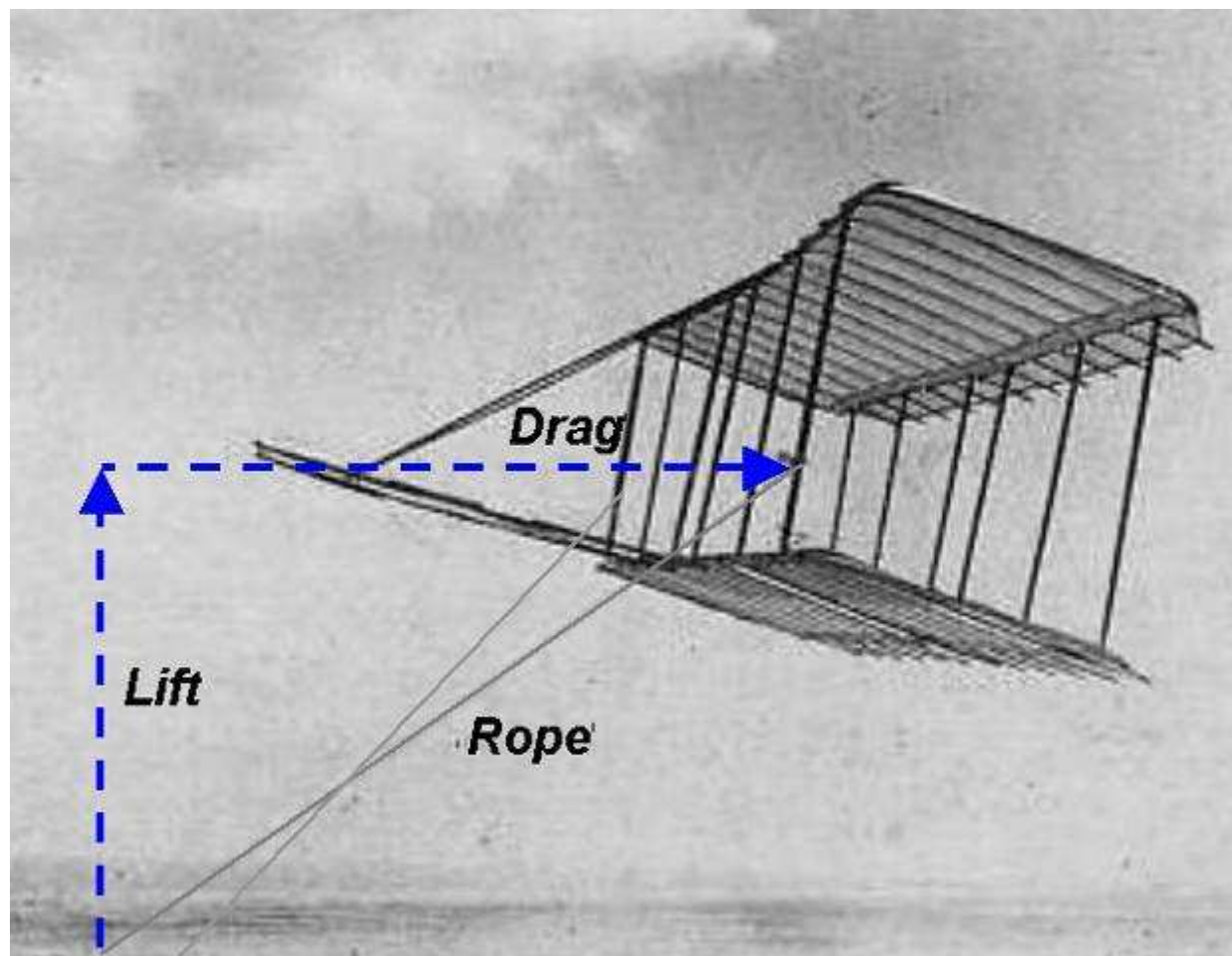



### *The wreck of the 1900 Wright Glider*

...a gust of wind had picked up the unattended craft and smashed it into the sand..

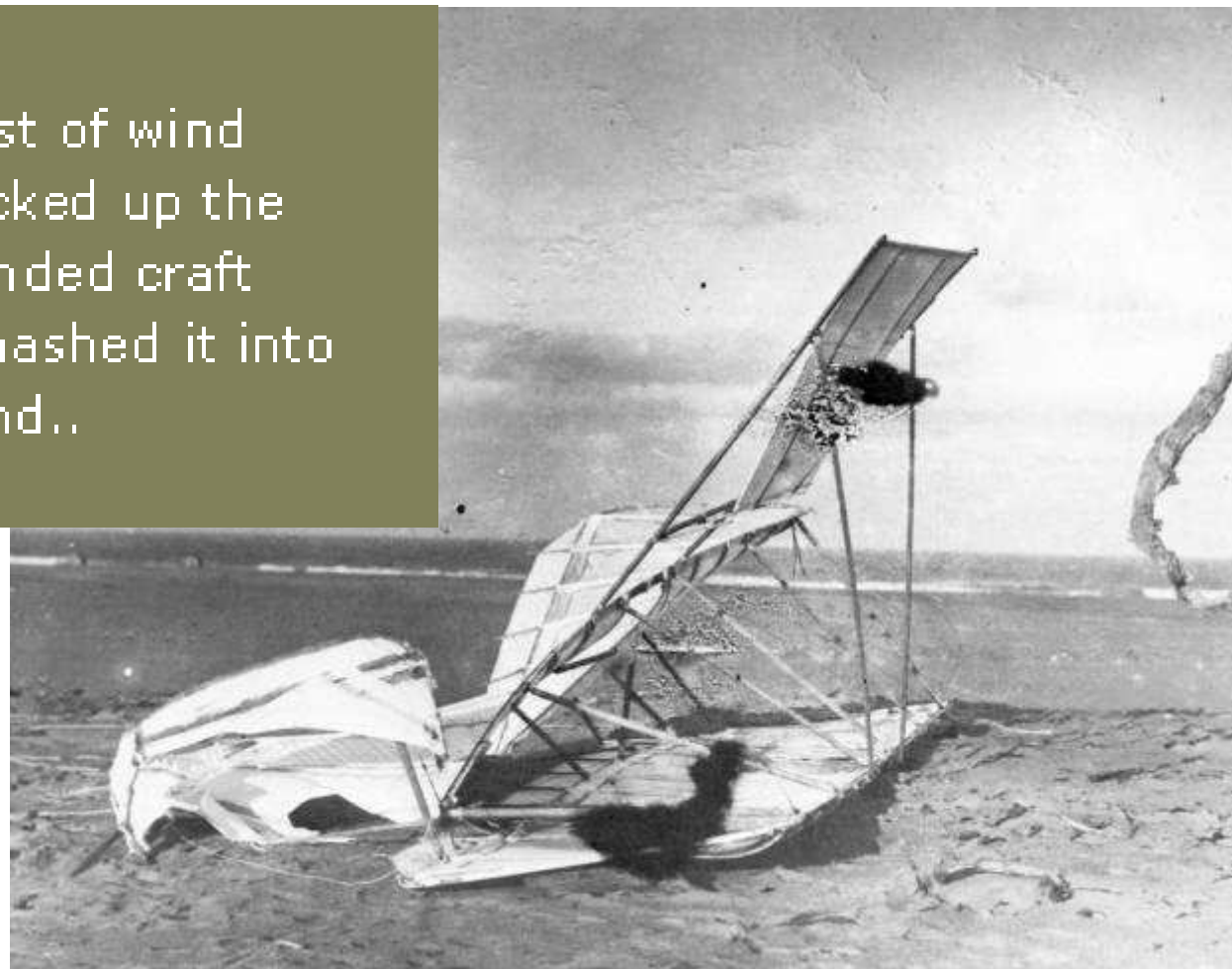



Dror Artzi

The brothers tested the idea of wing warping on the 1899 Wright Kite and, buoyed by its success, began developing full-size glider

No photographs exist of the 1899 kite; only a sketch of it illustrating wing-warping, drawn by Wilbur in 1912.

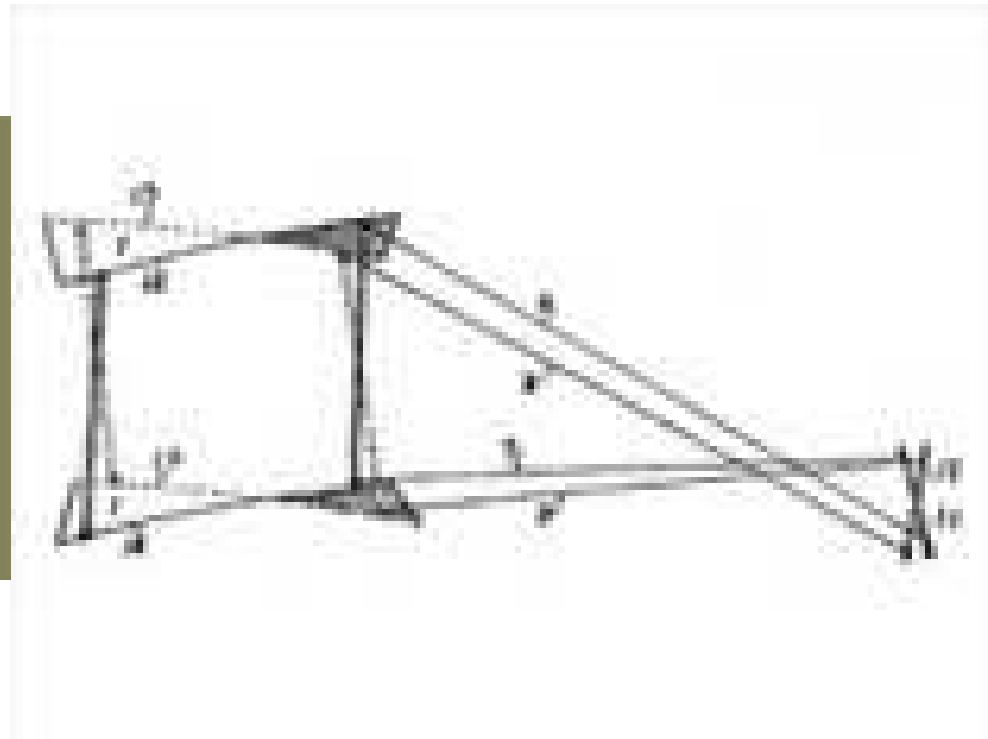



Dror Artzi

## Aircraft Control By Wing Warping

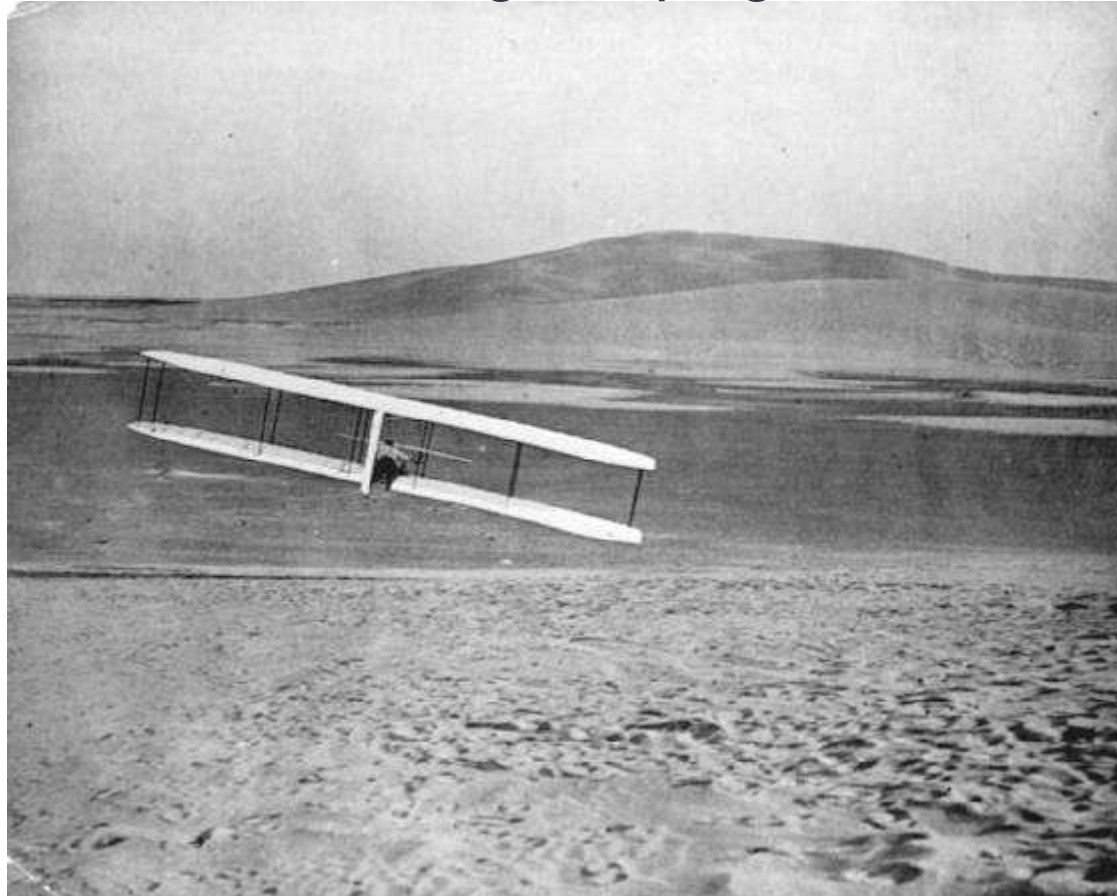

The brothers also made one of their key breakthroughs in 1899 - a light method of controlling balance and turning the aircraft which they called wing-warping.



Dror Artzi

## האחים רייט פעלו בתהליך מסודר של הערכת והורדת סיכונים.

ולכן, במעבר מדגם "המכונה" של 1900 לדגם של 1901  
החליטו האחים לבנות "מכונה" זהה  
מבחינת הביסוס התאורטי ושיטת ההפעלה

כדי לאפשר נשיאת "מפעיל" ע"י ה"מכונה"  
הוגדלה הכנף מ  $Ft^2$  165 ל  $Ft^2$  308  
ועקימון הפרופיל הוגדל מ 1 על 22 ל 1 על 12

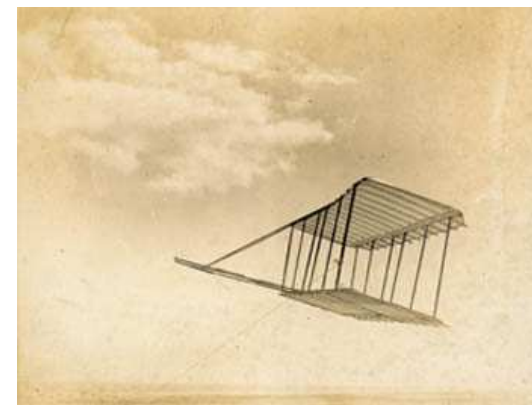
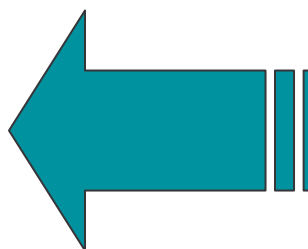
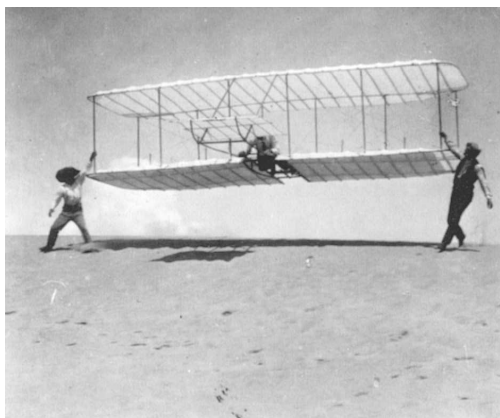



Dror Artzi

# תוכנית טיסה לקראת 1901

לקראת הטיסות ב 1901 בנו האחים תכנית טיסות ניסוי מפורטת כדלקמן :

When the wind blew 17 miles an hour or more we would attach a rope to the machine and let it rise as a kite with the operator upon it.

When it should reach a proper height the operator would cast off the rope and glide down to the ground as from the top of a hill .

בצורה זו נעשה 10 טיסות במקום אחת

בפועל מצאו האחים שרוח של 17 מייל אינה מסוגלת לשאת את משקל ה"מכונה" וה"מפעיל" משקל כולל של 240 ליברות בזווית הכוונה של 3 מעלות אלא את משקל ה"מכונה" בלבד – 100 ליברות

כלומר – בקושי שליש מכוח העילוי המחושב



Dror Artzi

חשד ראשון – בד הכנף פורוסיבי מידי

בניית שני דגמי ניסוי בגודל שווה

מעטה כנף אטום למעבר אוויר

מעטה כנף ללא טיפול לאטימה

but we could detect no difference  
in their lifting powers.

4 סיבות אפשריות

וכשיש כזה פער  
מבצעים ניתוח תוצאות

- (1) the anemometer used by us **over recorded** the true velocity of the wind by nearly **15 percent**;
- (2) that the well-known **Smeaton coefficient of  $0.005V^2$**  for the wind pressure at  $90^\circ$  is probably too **great by at least 20 per cent**;
- (3) that Lilienthal's estimate that the **pressure on a curved surface** having an angle of incidence of  $3^\circ$  equals 0.545 of the pressure at  $90^\circ$  is too large, being nearly **50 per cent greater** than very recent experiments of our own with a special pressure-testing machine indicate;
- (4) that the **superposition of the surfaces** somewhat **reduced the lift** per square foot, as compared with a **single surface of equal area**.



Dror Artzi

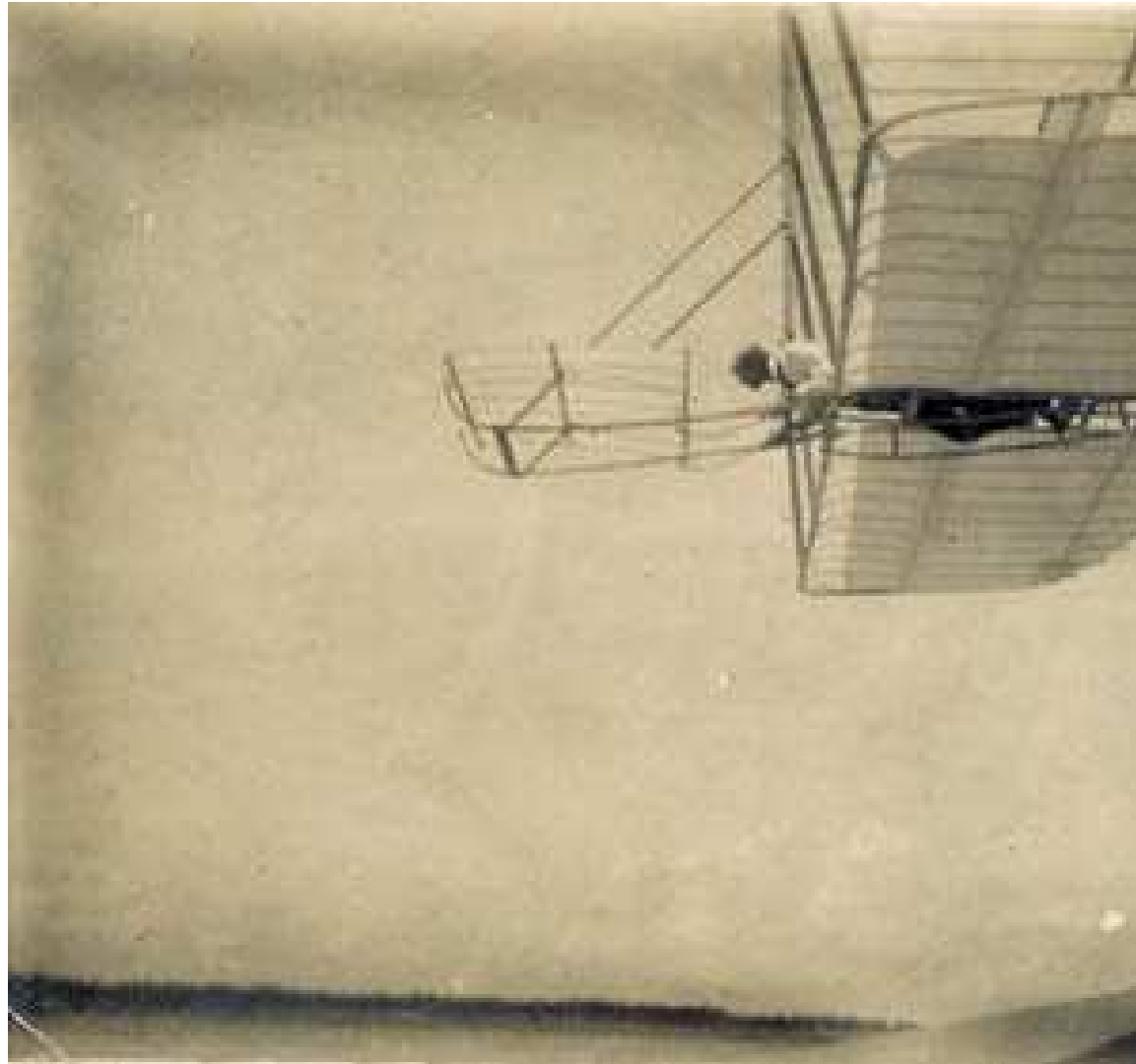

Wilbur At The Controls of the Unruly 1901 Glider



Dror Artzi

## Launching the 1901 Wright Glider.

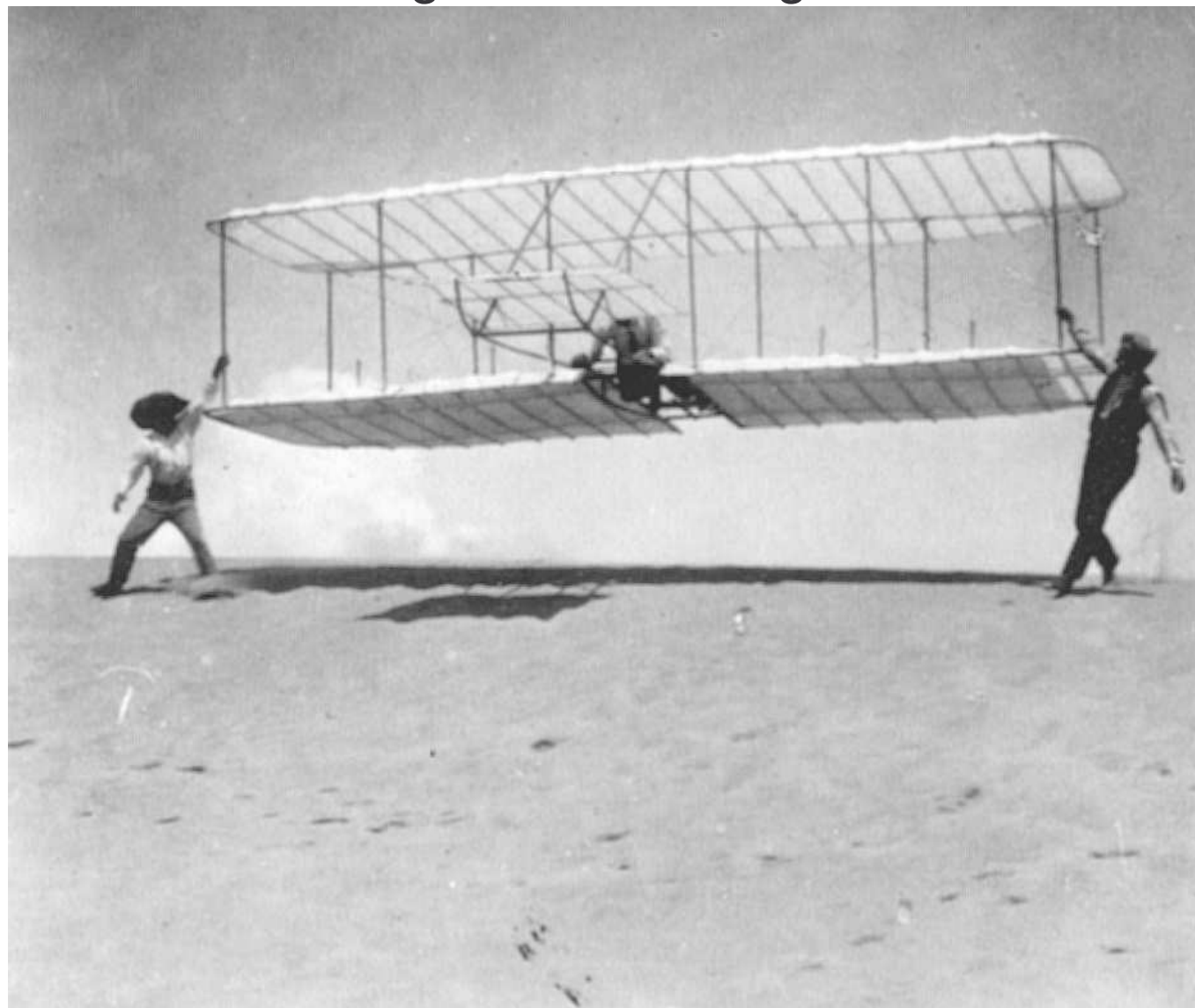



Dror Artzi

## Orville Posed With the Completed 1901 Glider

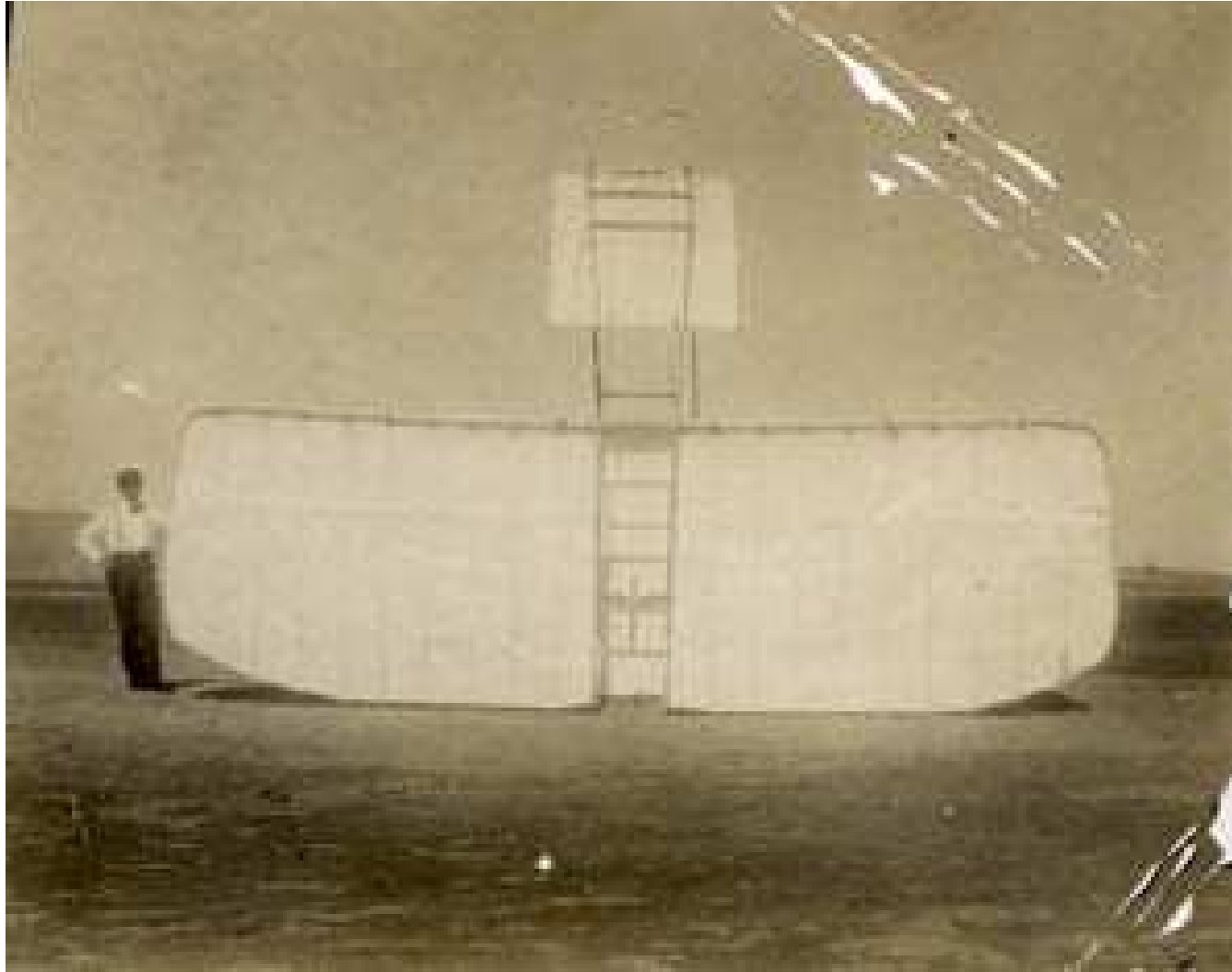



Dror Artzi

# 1901 Glider

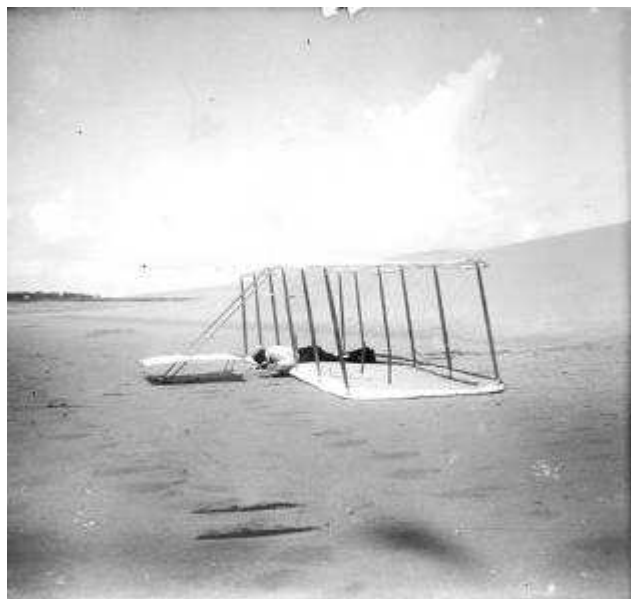
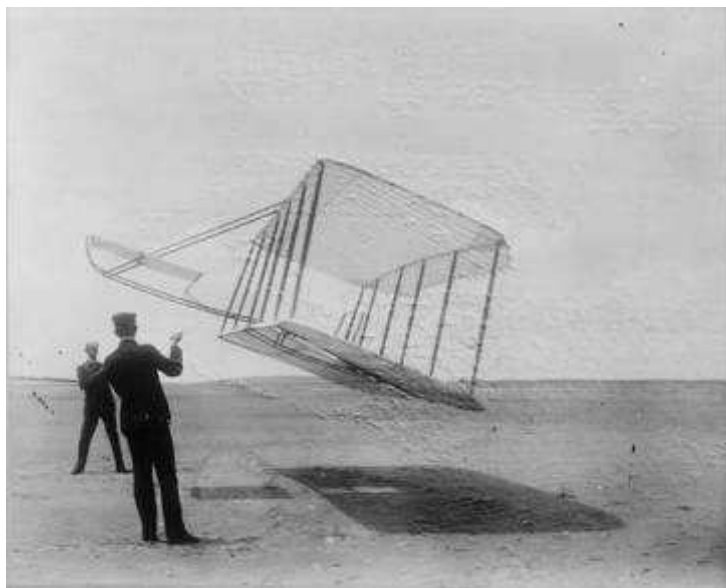
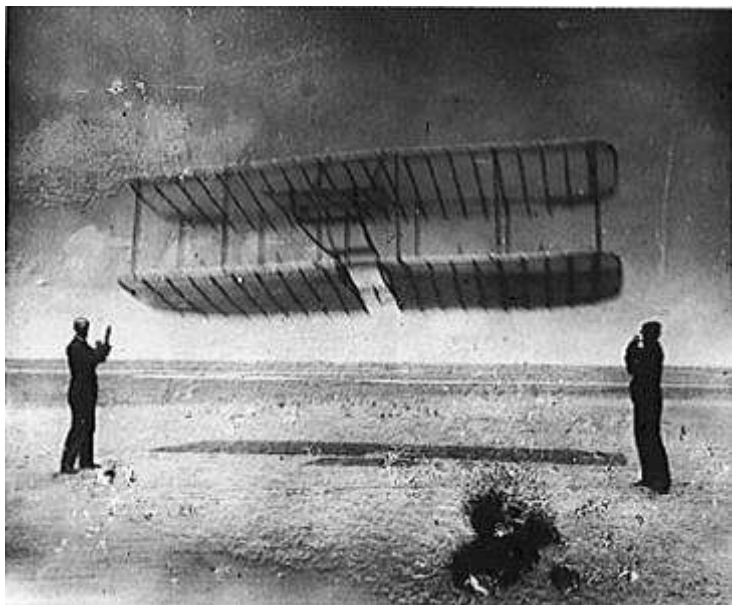



Dror Artzi

1901

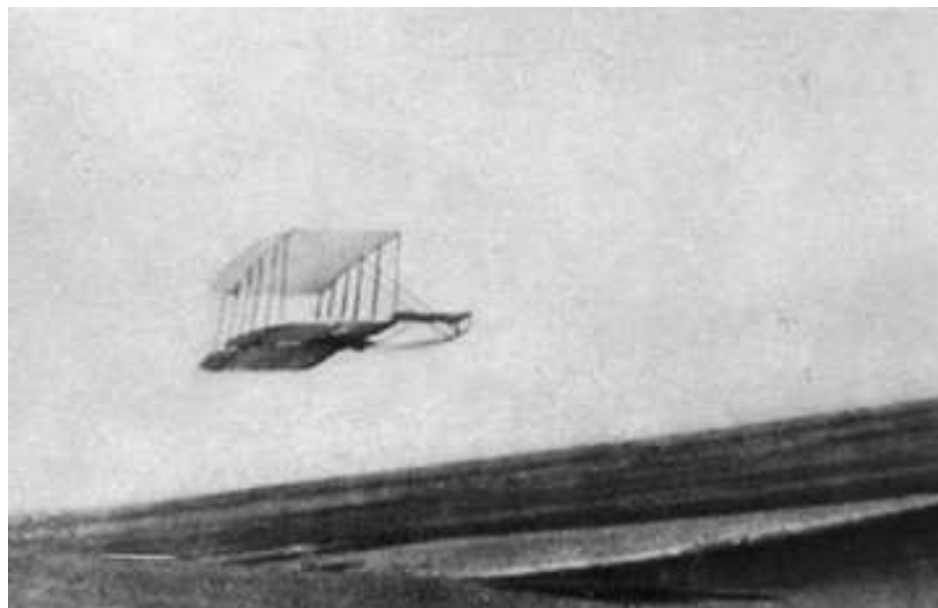



Dror Artzi

**“When we left Kitty Hawk at the end of 1901,”  
Wilbur recalled a decade later,  
“we doubted we would ever  
resume our experiments.”**

**Orville’s memory was of his brother’s  
exasperation on the long trip home,  
when at one point he had remarked:**

**“Not within a thousand years  
would man ever fly!”**





Dror Artzi

ב 18 לספטמבר 1901 מרצה ווילבור רייט בפני

ה - *Western Society of Engineers*

נשיא האקדמיה Mr. Chanute  
בהקדמתו להרצאה אומר:



These gentlemen have been **bold enough**  
to attempt some things which neither Lilienthal,  
. nor Pilcher, nor myself dared to do



בטיסות של 1901 בחנו האחים  
את הקשר בין מהירות הרוח, זווית ההתקפה של הפרופיל  
ותזוזת מרכז הלחץ

$P$ , center of pressure;  $G$ , center of gravity.

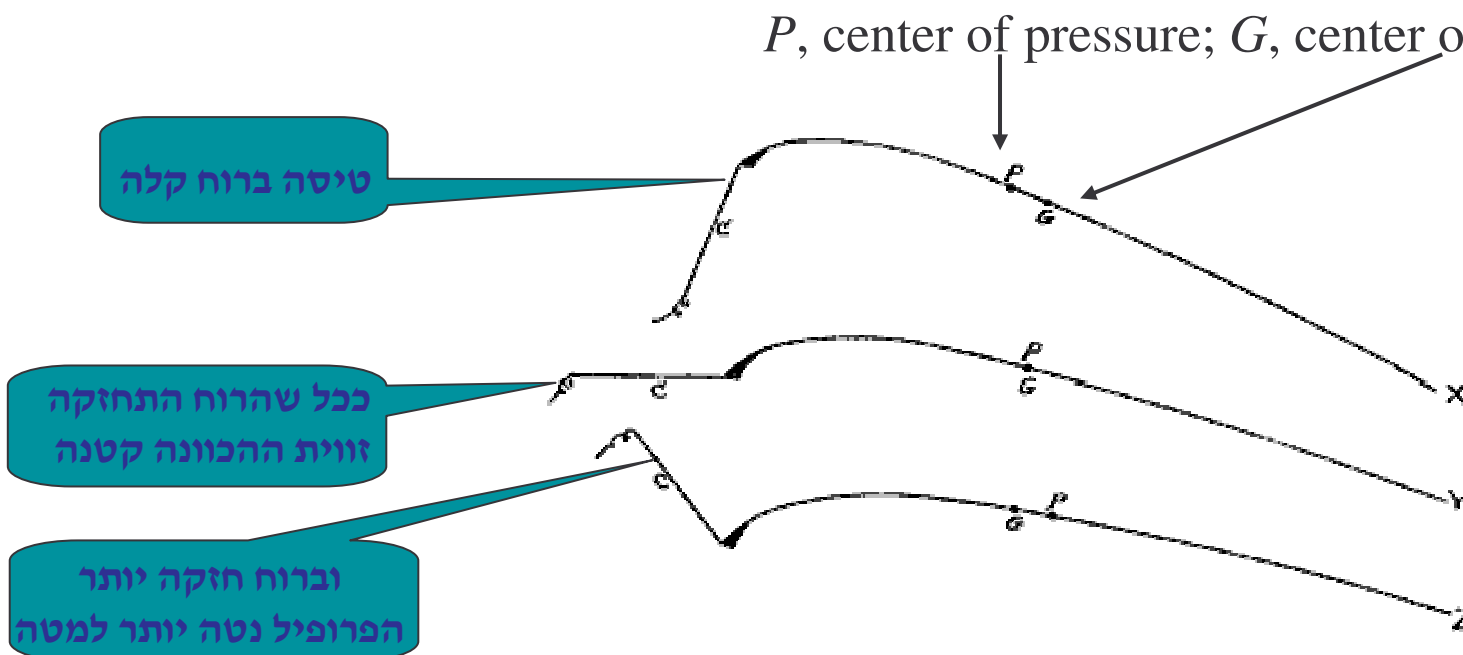

It at once occurred to me that here was the answer to our problem, for it is evident that in the first case the center of pressure was in front of the center of gravity, and thus pushed up the front edge; in the second case they were in coincidence and the surface in equilibrium, while the third case the center of pressure had reached a point even behind the center of gravity, and there was therefore a downward pull on cord



Dror Artzi

## כשהמשוואות לא עובדות ממציאים ובונים מנהרת רוח, באלאנס (מאזניים) ומריצים מאות ניסויים

At the end of the summer of 1901, the Wright brothers were **frustrated** by the flight tests of their 1901 glider. The aircraft was flown frequently up to **300 feet in a single glide**. But the aircraft **did not perform** as well as the brothers had expected. The aircraft only developed 1/3 of the lift which was predicted by the lift equation using Lilienthal's data.

The brothers began to question the aerodynamic data on which they had based the design of their 1900 and 1901 gliders. They decided to measure their own values of lift and drag with a series of wind tunnel tests.

To resolve this problem, they built a wind tunnel and tested 200 wing shapes before settling on the best design for their third glider.

To measure the lift and drag, the brothers built small models of their wing designs and placed them on a measuring device called a **balance**.

There were two balances, one for lift and the other for drag.



Dror Artzi



The Wrights' Home-Built Wind Tunnel  
Provided Much New Data



Dror Artzi



# 1901 Wind Tunnel

Glenn  
Research  
Center

Side View

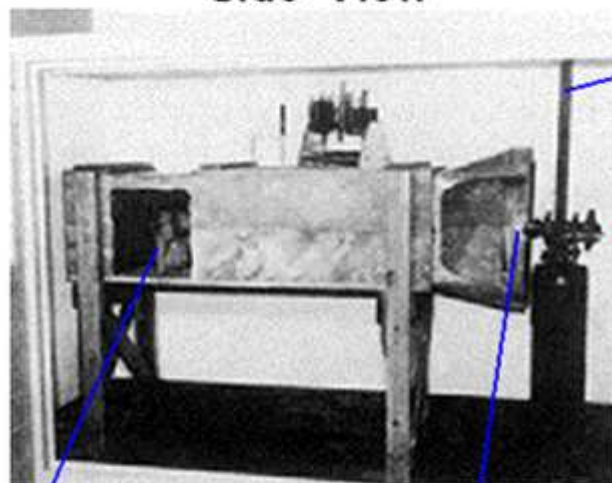

Test Section

Fan

Shop Belt Drive



Flow  
Direction

View Window

Fan

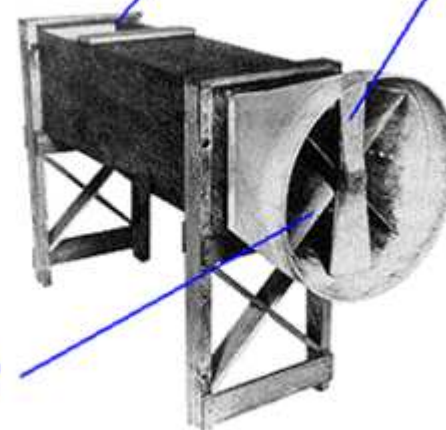

Straightener



Dror Artzi

Wilbur and Orville conducted tests on  
as many as 200 wing shapes

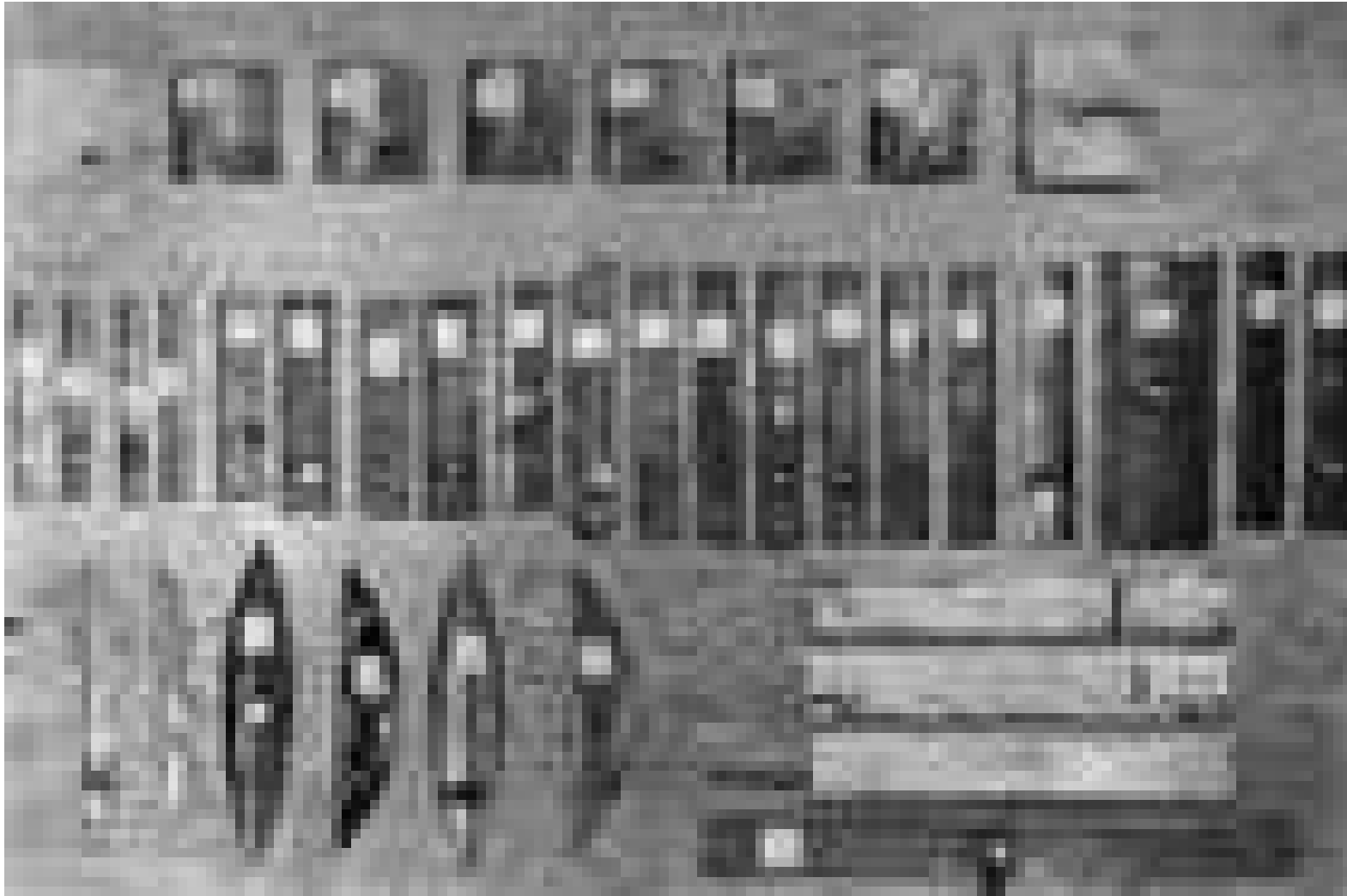



Dror Artzi

These are examples of the model wings the Wright brothers tested in their wind tunnel. They made them from sheet steel using tin shears, a hammer, and a file.





# Wind Tunnel Test Models #1

Photos courtesy of the Franklin Institute

Glenn  
Research  
Center

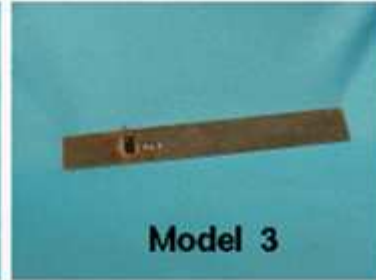
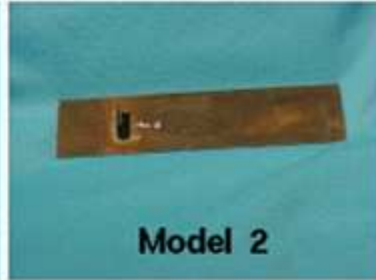
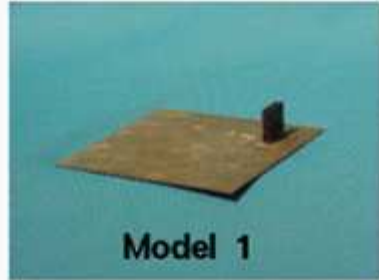

Aspect ratio test, flat plates

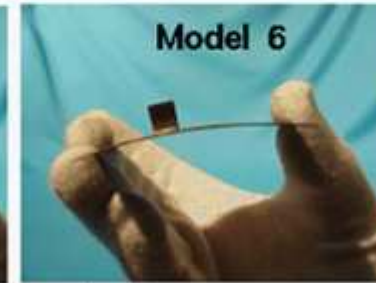
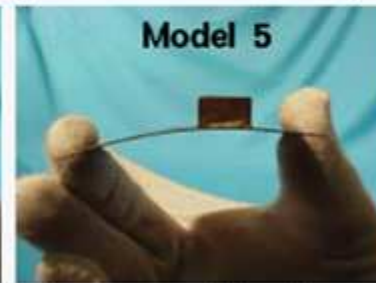
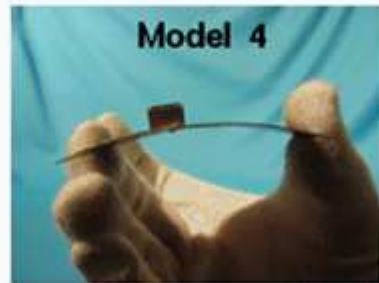

Camber test, arc foils, low aspect ratio



Camber test, arc foils, high aspect ratio



## Wind Tunnel Test Models #2

Photos courtesy of the Franklin Institute

Glenn  
Research  
Center

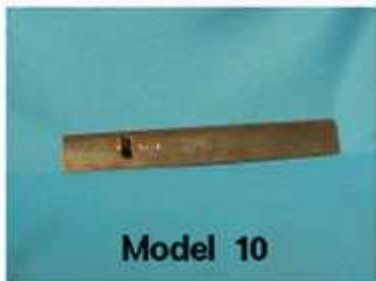

Model 10

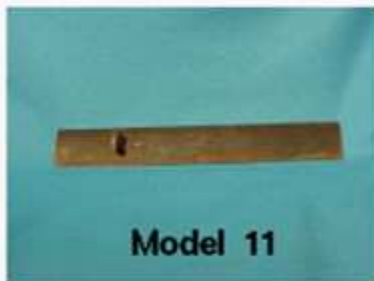

Model 11



Model 12

(Bottom View)

Camber test, parabolic foils, high aspect ratio



Model 15



Model 16

Model 17

Photo Not Available

Camber test, parabolic foils, low aspect ratio

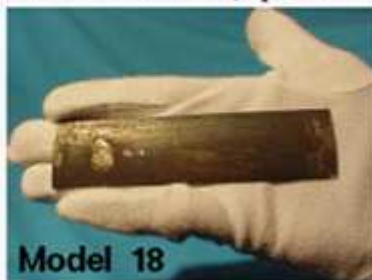

Model 18



Model 19

Aspect ratio tests at low camber



# Wind Tunnel Test Models #3

Photos courtesy of the Franklin Institute

Glenn  
Research  
Center



Model 20



Model 21



Model 25

Identical to Model 32

Wing tip geometry tests



Model 23

Identical to Model 22  
and Model 26

Multiple wing tests



Model 35

Cross section test



Model 30



Model 31

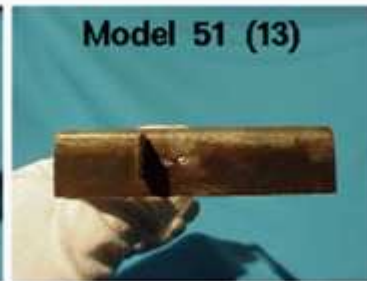

Model 51 (13)

Special Models



Dror Artzi

*The homemade "lift balance" that the Wright brothers used to measure the lift and drag of various wing shapes in their wind tunnel*

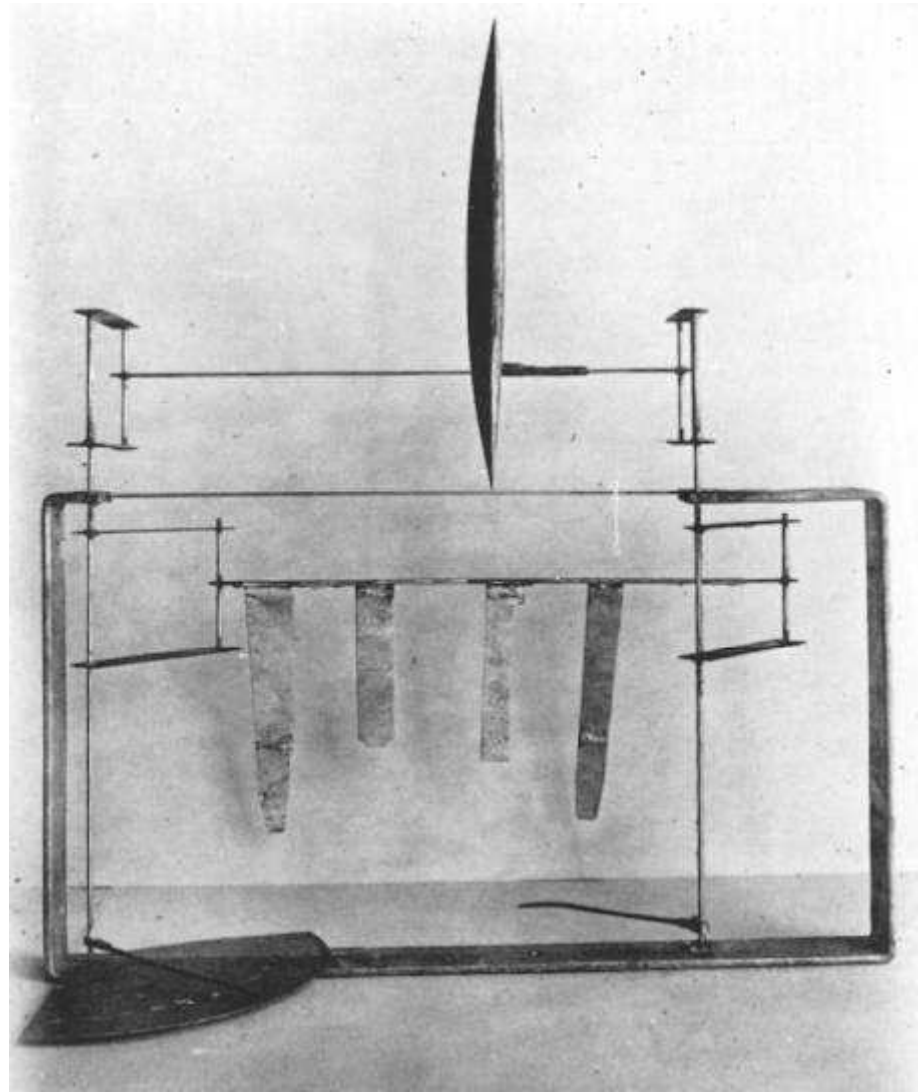



# Wright 1901 Drag Balance Design

Glenn Research Center

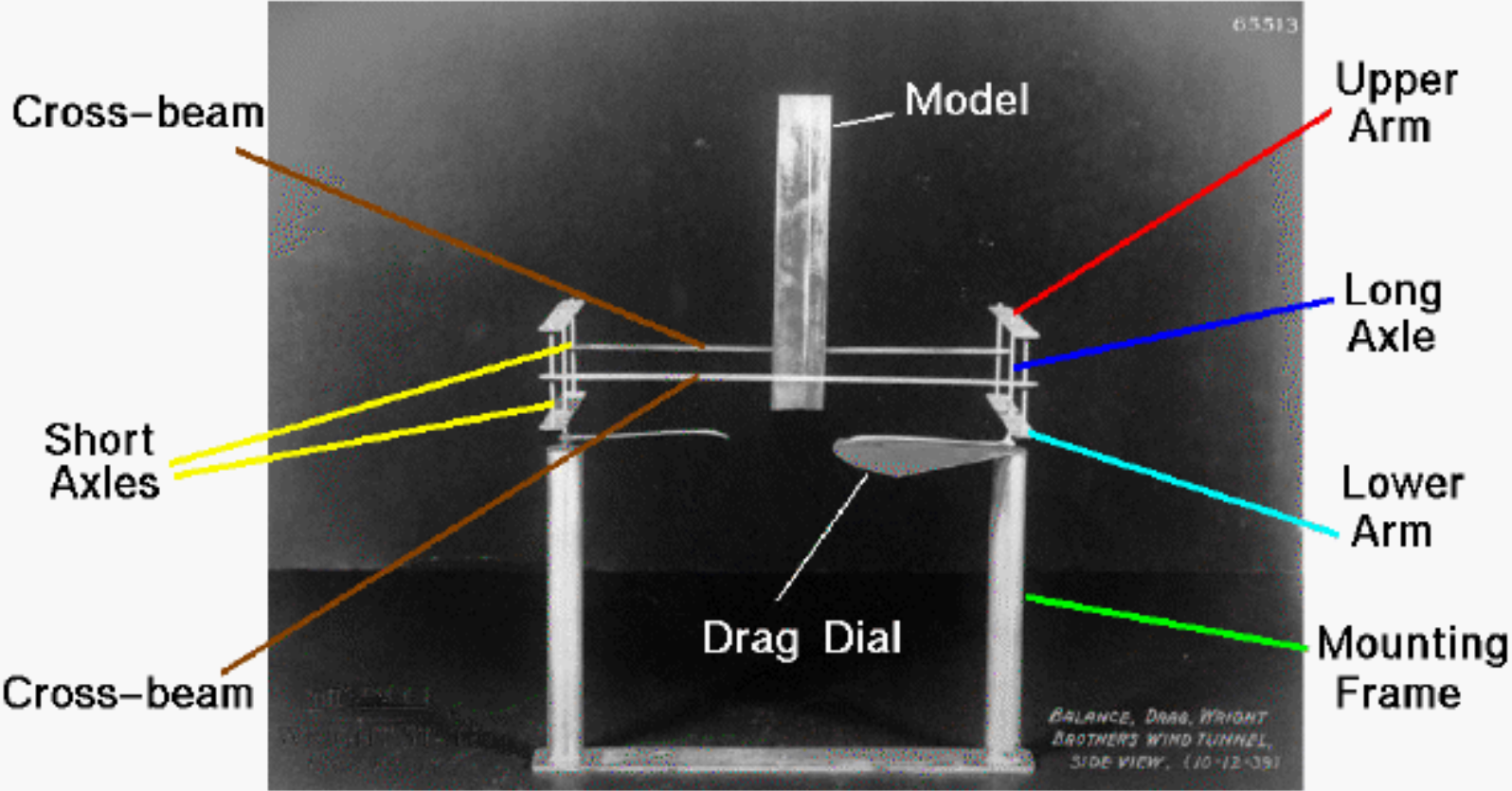

Side View

BALANCE, Drag, WRIGHT BROTHERS WIND TUNNEL, SIDE VIEW, (10-12-09)



# Wright 1901 Lift Balance Design

Glenn Research Center

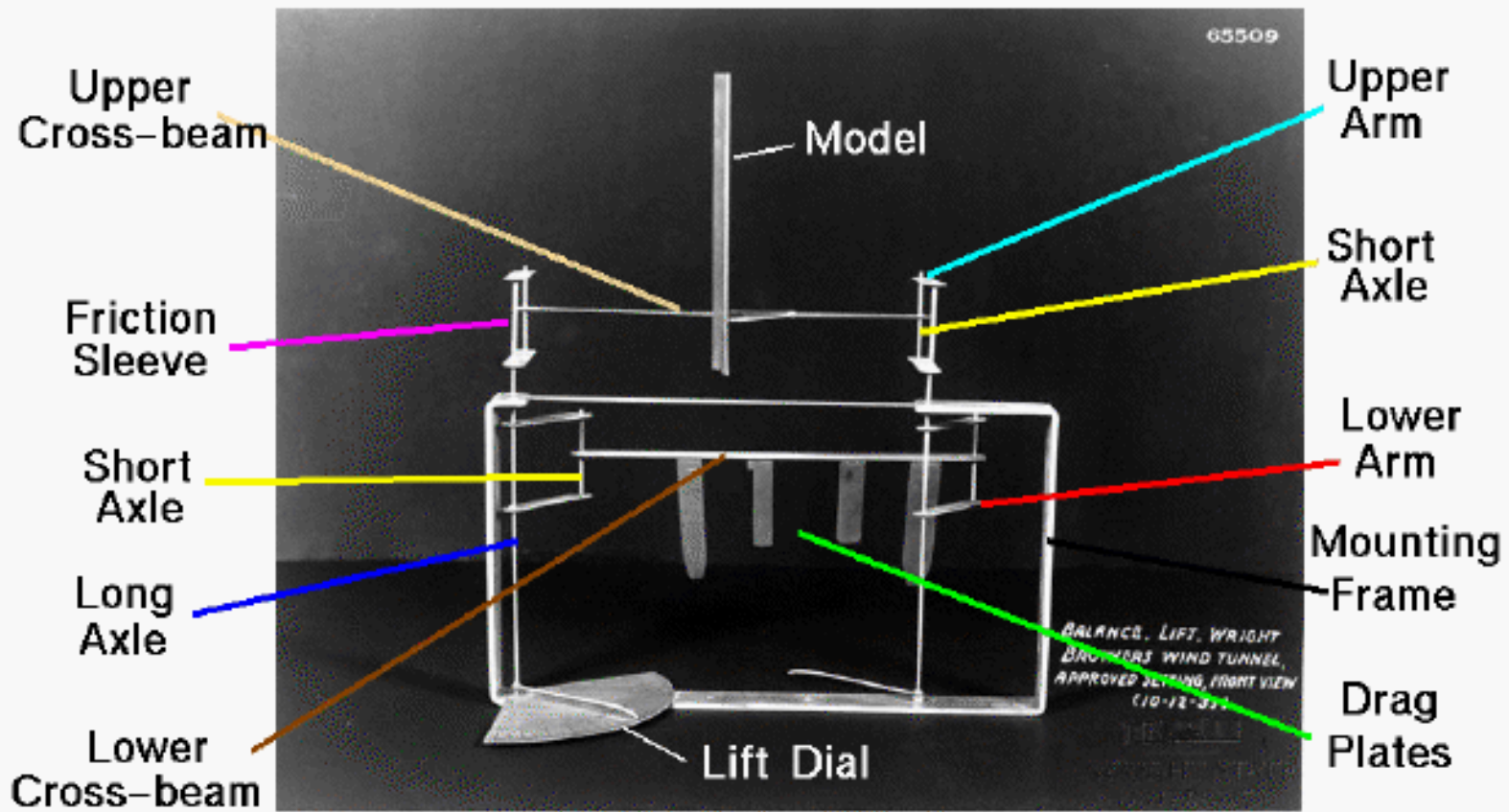

View Looking Downstream



## Wright 1901 Drag Balance Operation

Glenn  
Research  
Center

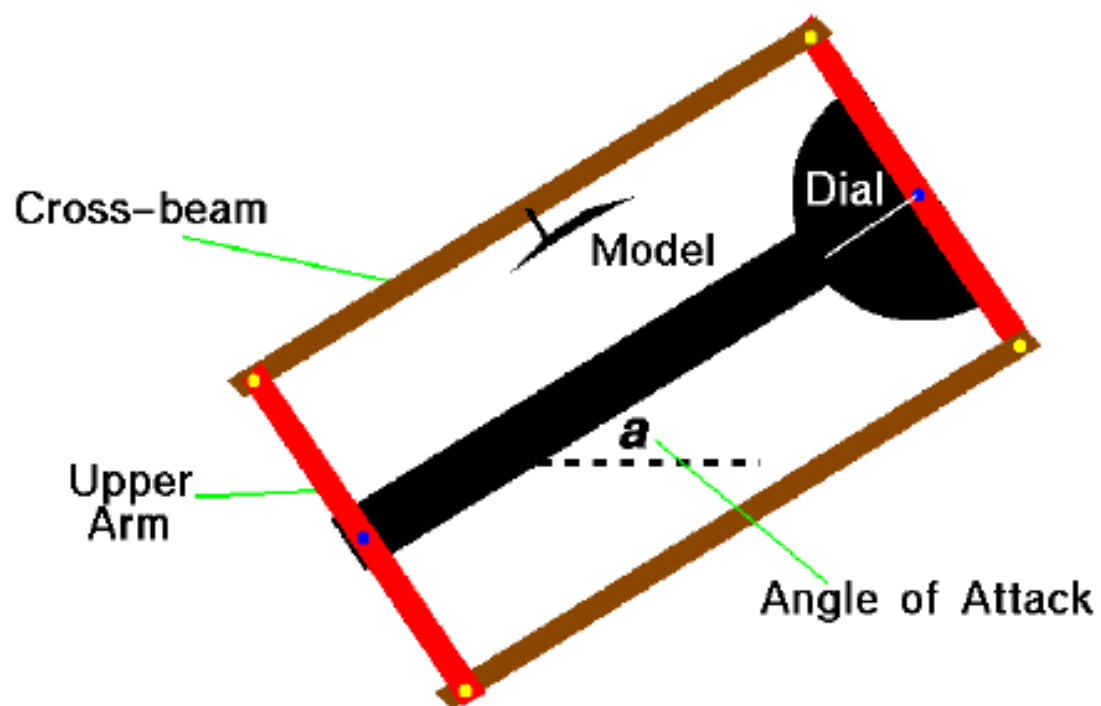

Figure 1. Initial Balance Conditions.  
*View from above*



## Wright 1901 Lift Balance Operation

Glenn  
Research  
Center

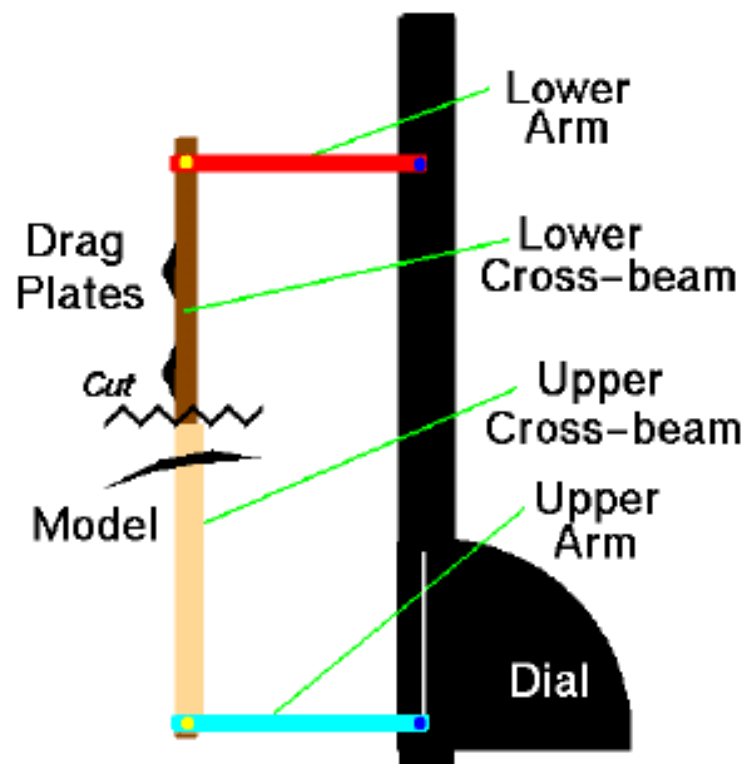

Figure 1. Initial Balance Conditions.  
*Upper beam cut and removed for viewing  
from above.*

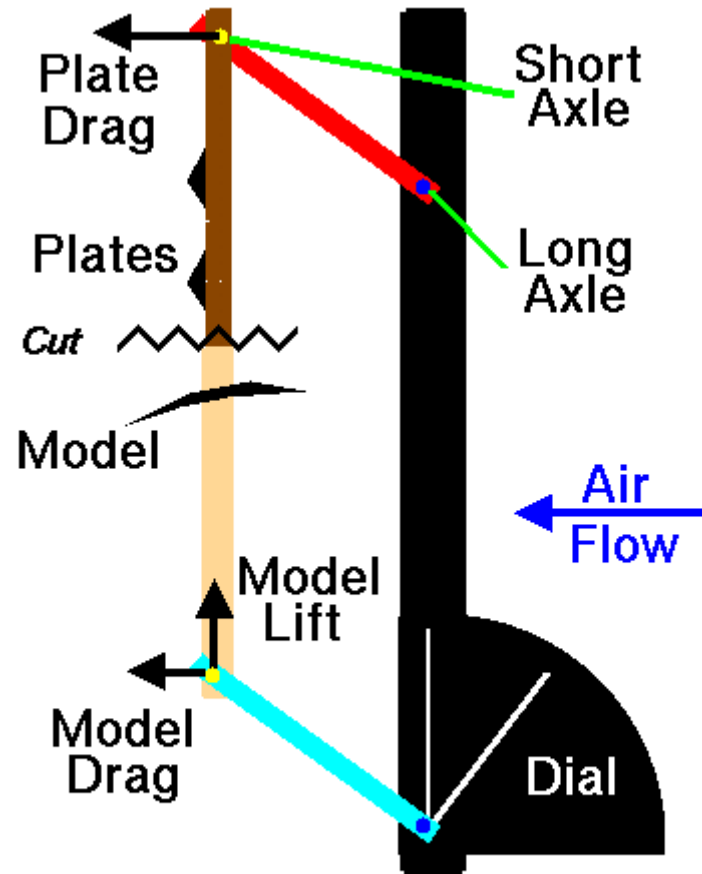

Figure 2. Tunnel Started.  
*Upper beam cut and removed for viewing*

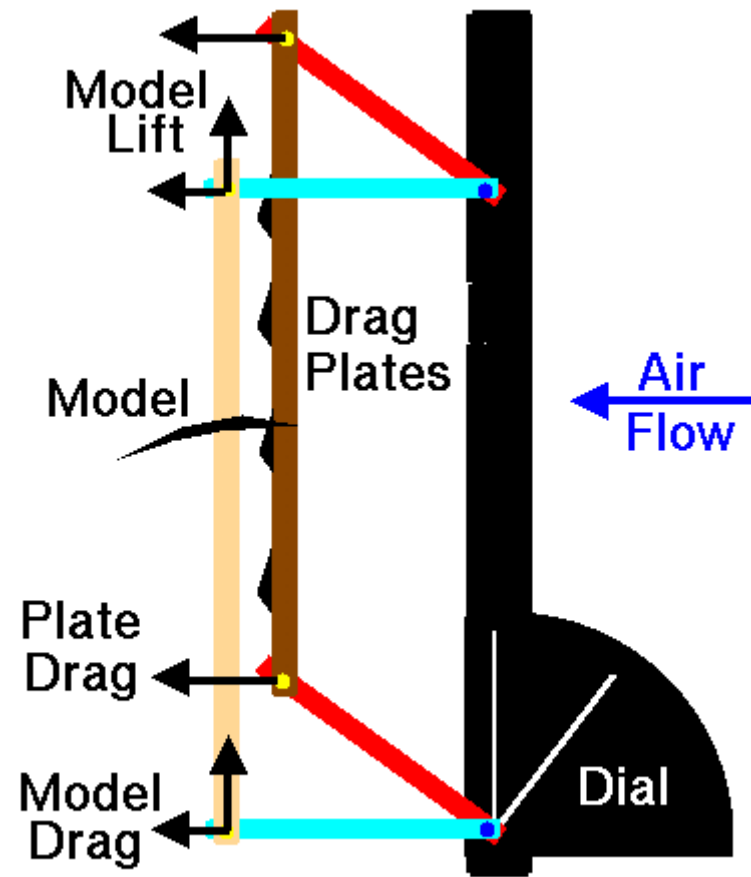

Figure 3. Adjustment for Model Drag

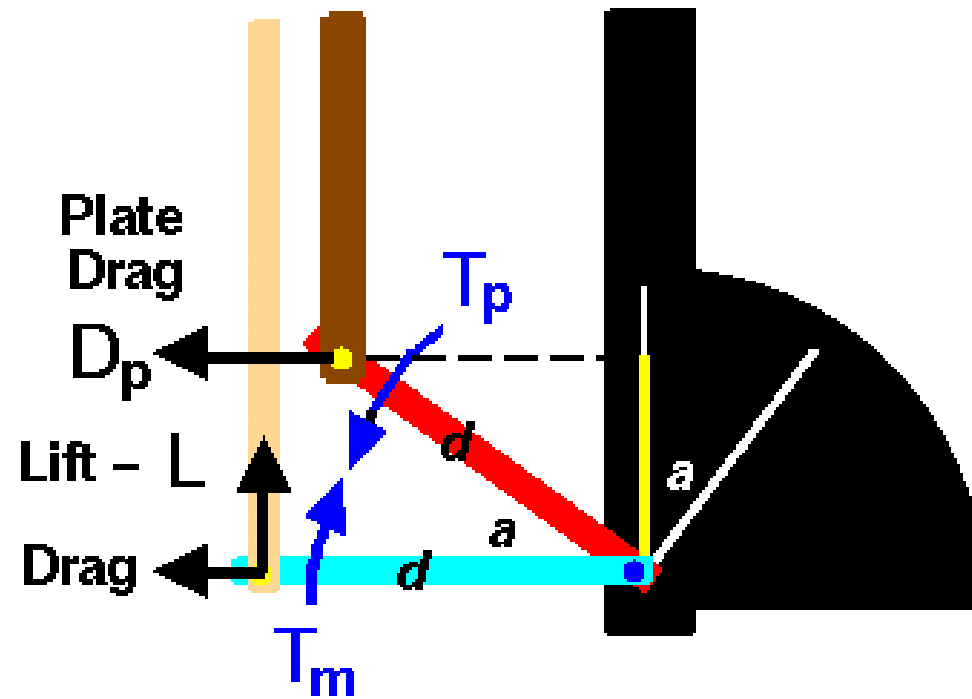
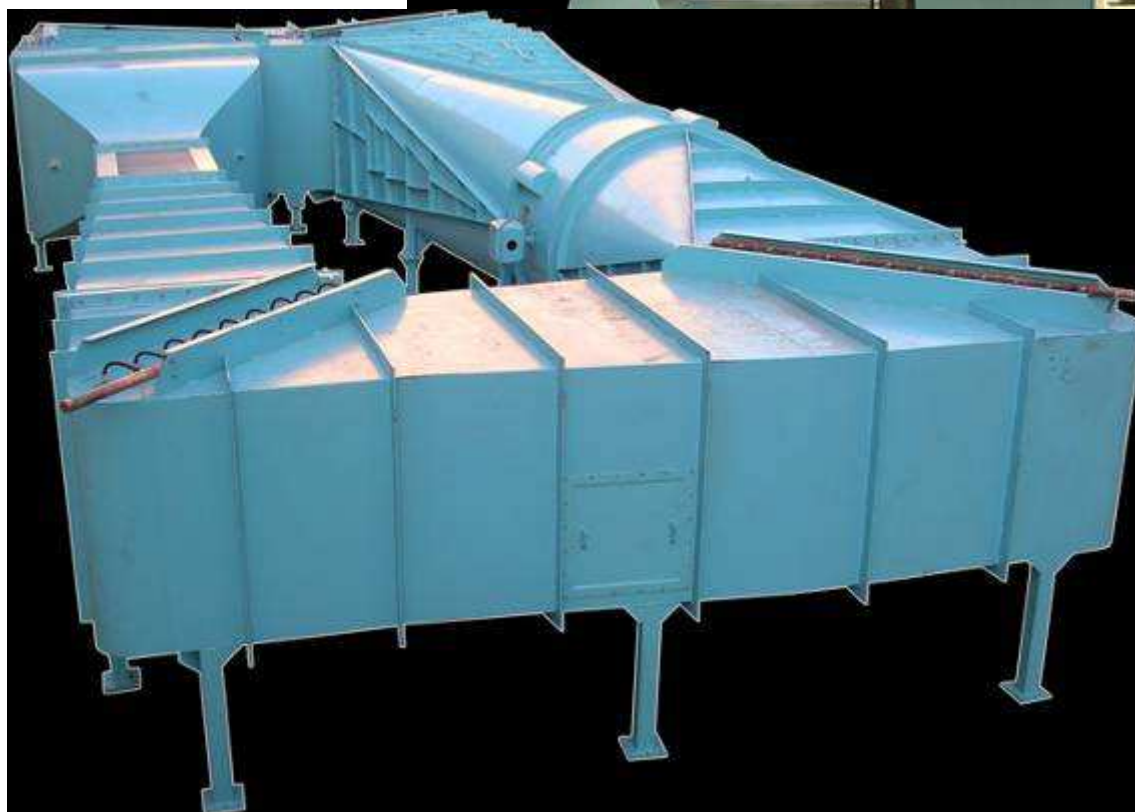
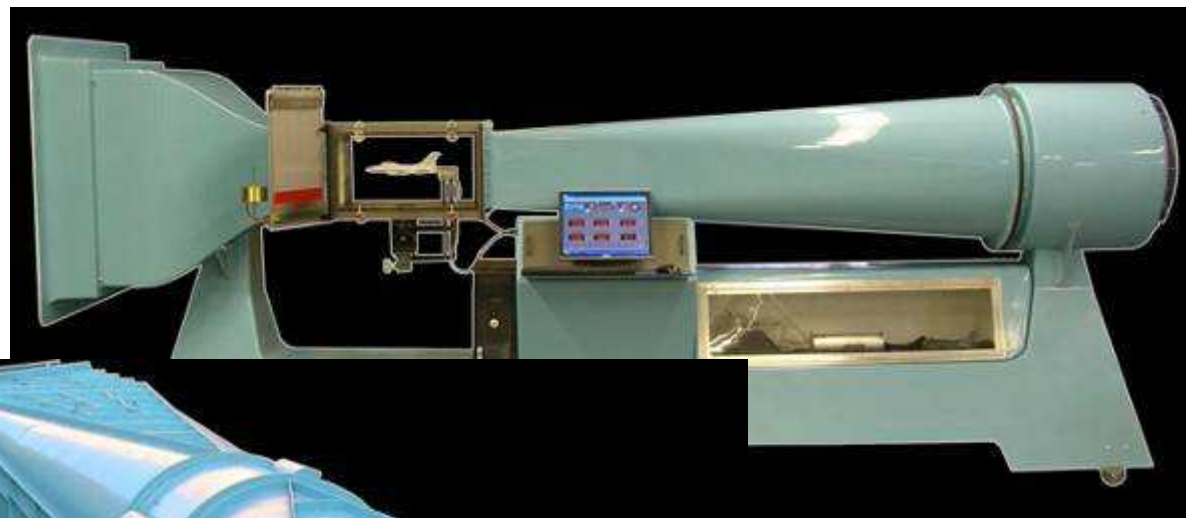

Figure 4. Torques on the Long Axles.



Dror Artzi

# והיום





Dror Artzi

## מיג 21 בניסוי מנהרה

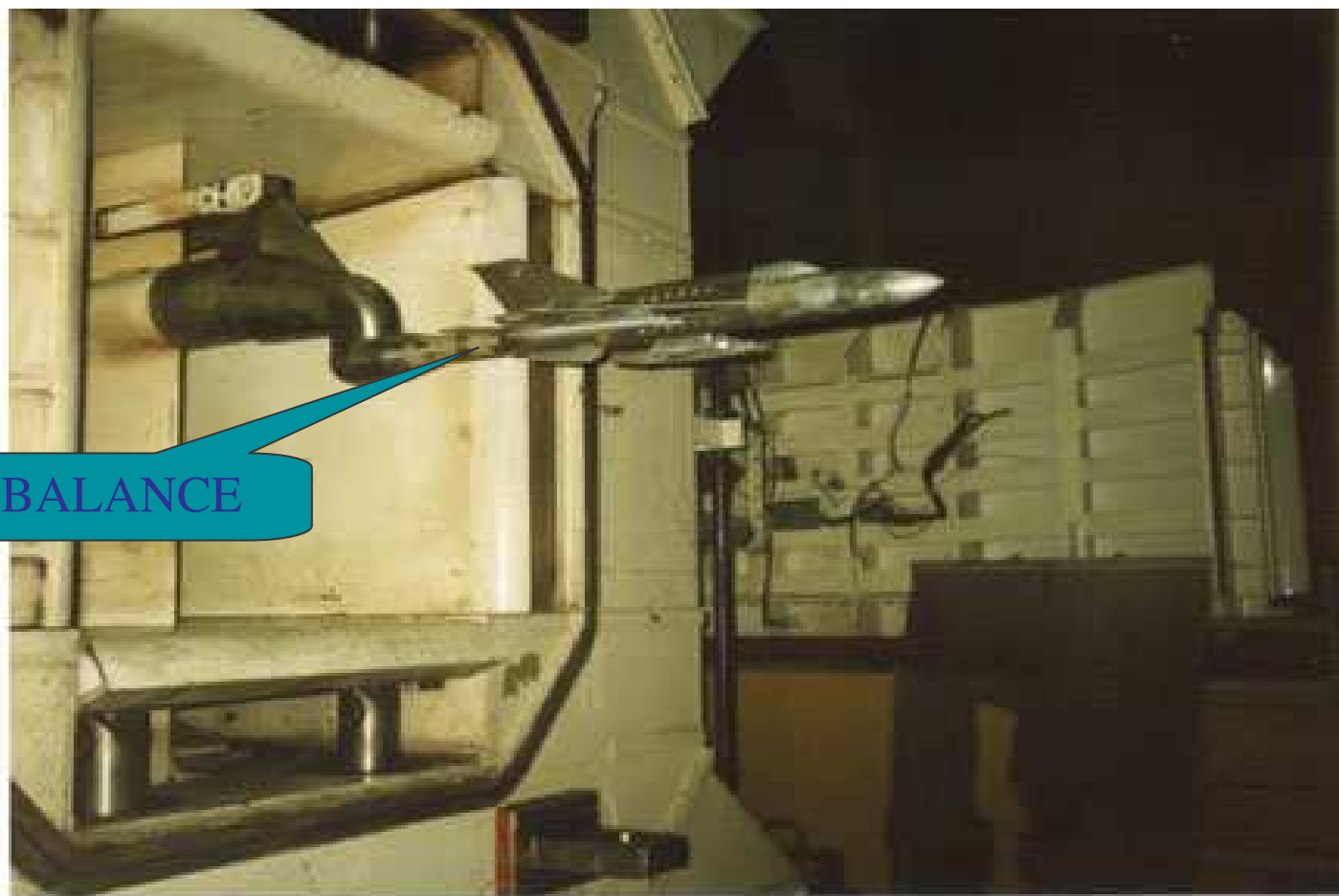

BALANCE



Dror Artzi

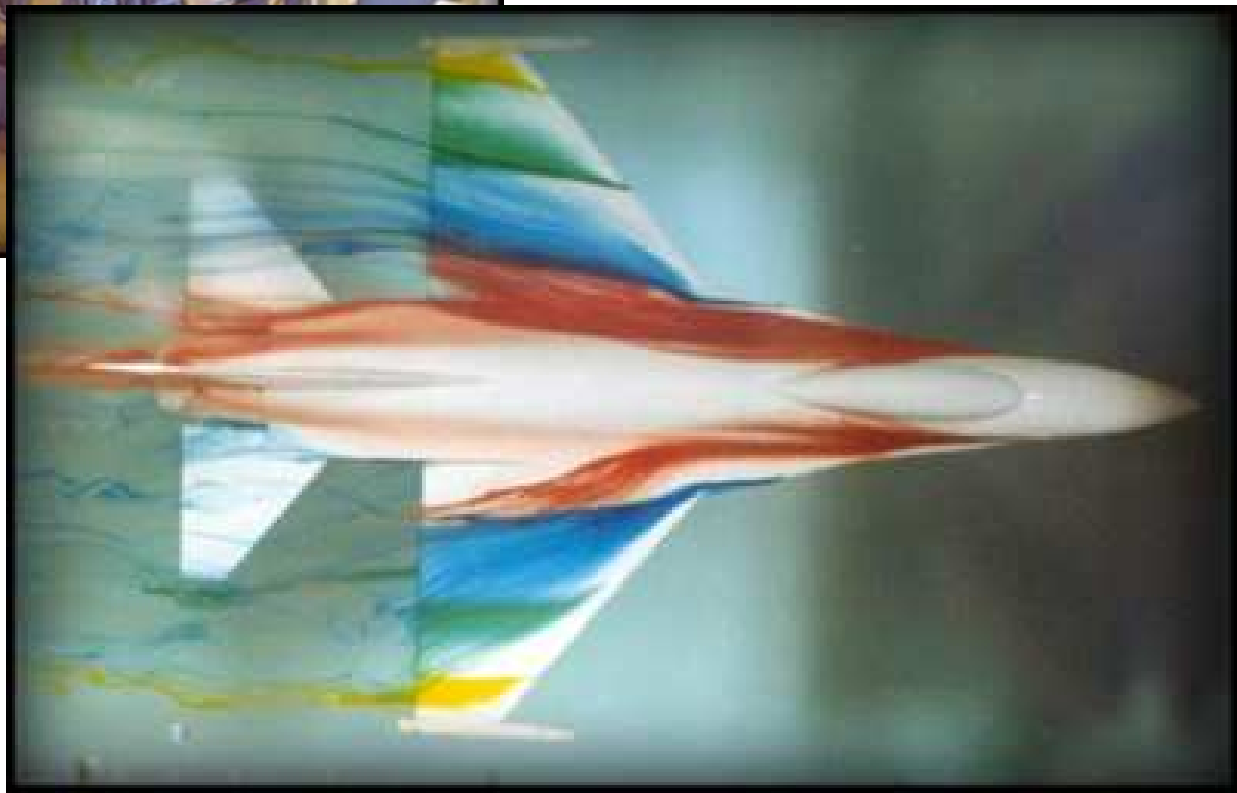



Dror Artzi





Dror Artzi

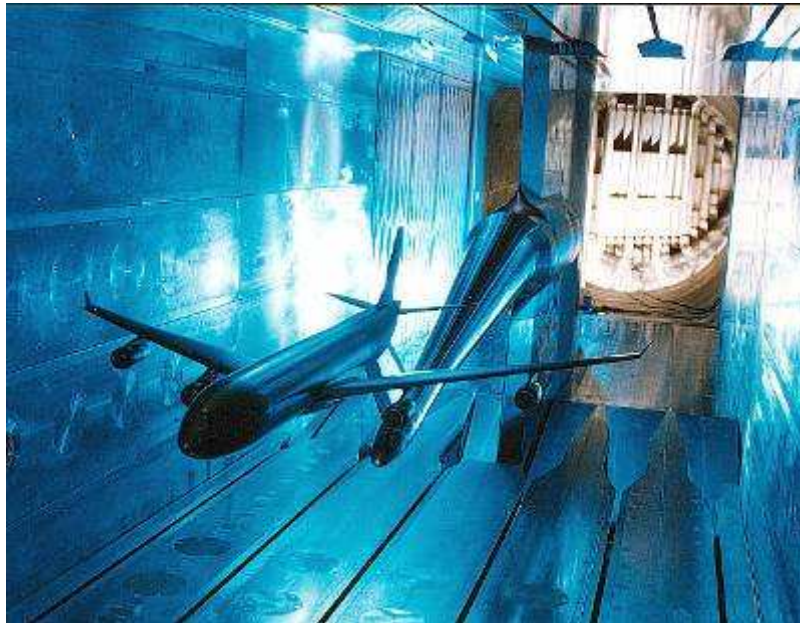



Dror Artzi







Dror Artzi

# מתוך הרצאתו של ווילבור רייט

(ספטמבר 1901)

הקשיים בדרך לבניית מכונה מעופפת הם משלושה סוגים:

- בניית כנף עם יכולת נשיאה
- בניית הכוח המניע שיאפשר לדחוף את המכונה דרך האוויר
- יכולת השליטה באיזון ובהיגוי של המכונה אחרי שהצלחנו להרימה באוויר

על שני הקשיים הראשונים פחות או יותר התגברנו,  
נושא היציבות וההיגוי הם עדיין האתגר.



## ועוד

ישנן שתי דרכים ללמוד לרכב על סוס עצבני:  
לעלות עליו וללמוד איך להגיב נכון לכל תנועה וטריק שלו

או

לשבת על הגדר ולהתבונן בחיה ואז לפרוש הביתה ובניחותא לפענח מה  
הדרך הטובה להתגבר על קפיצותיו ובעיטותיו של הסוס.

זה ממש דומה כשאתה מנסה ללמוד לרכב על מכונה מעופפת  
יותר בטוח לשבת על הגדר

אך אם באמת ברצונך ללמוד אתה צריך לבנות מכונה  
וללמוד להכיר את כל הטריקים שלה בניסיונות אמיתיים



Dror Artzi



the Wrights returned to Kitty Hawk on August 27, 1902,  
for their third fall of testing,



Dror Artzi

## The 1902 Wright Glider in flight

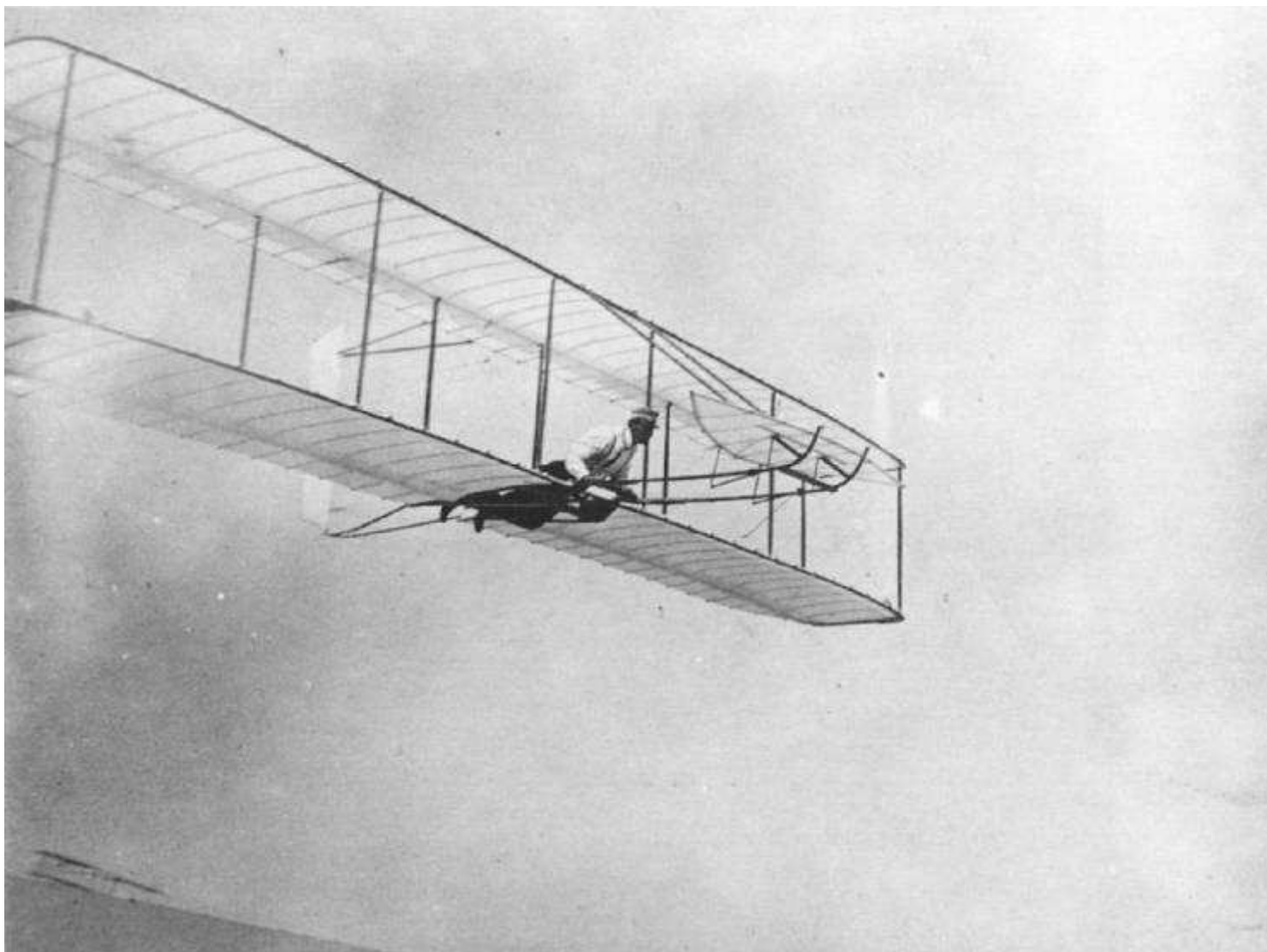



Dror Artzi

1902

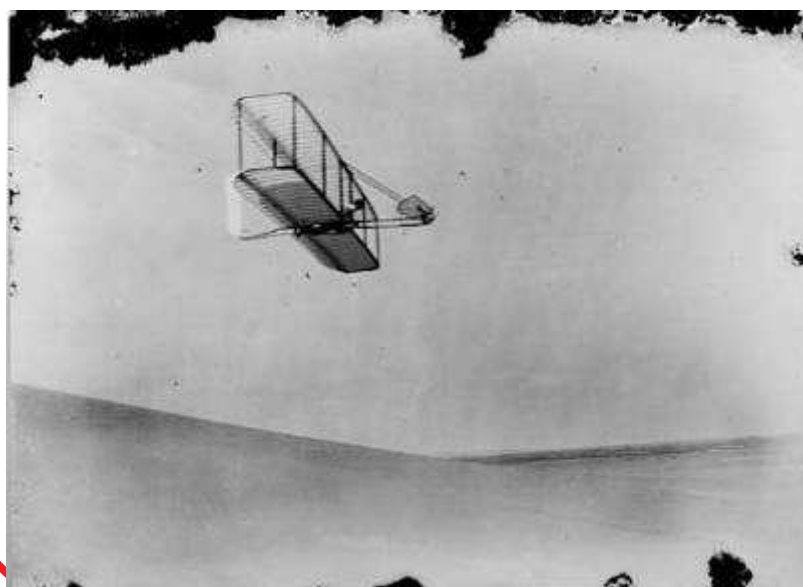
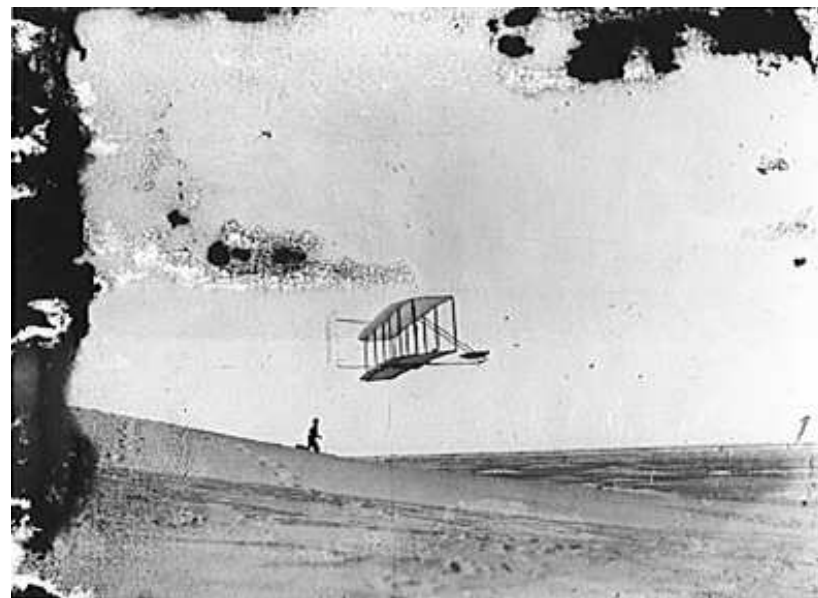



Dror Artzi



On October 23 , 1902  
Wilbur set a record for time and distance,  
sailing 622.5 feet in 26 seconds.



Dror Artzi

The Wrights used this French-made, hand-held anemometer to measure wind speeds





Dror Artzi

*The plans for the  
1903 Wright Flyer 1  
that the  
Wright brothers drew  
on a piece of brown  
wrapping paper.*

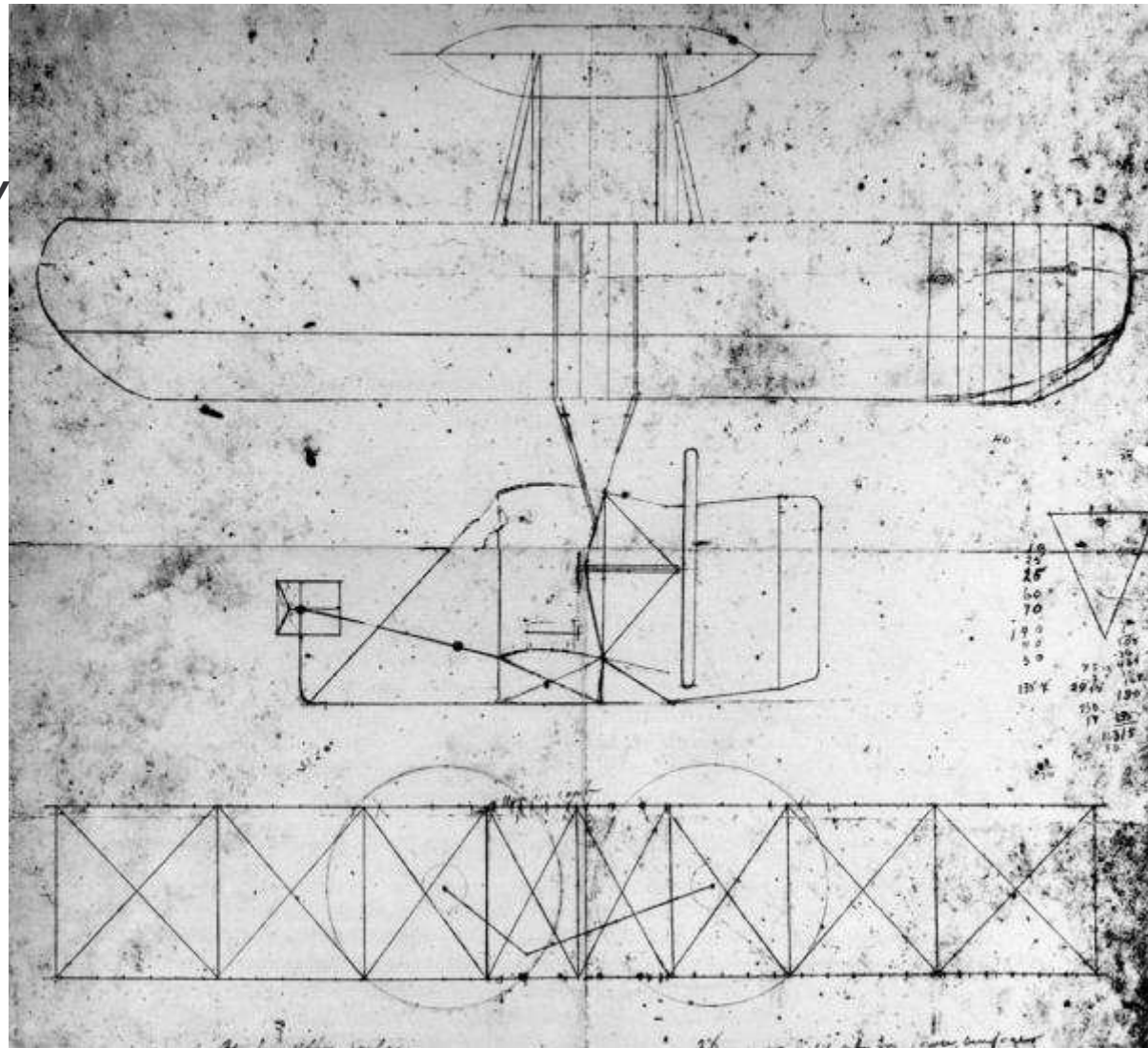



# Parts of an Aircraft

Wright 1903 Flyer

Glenn  
Research  
Center

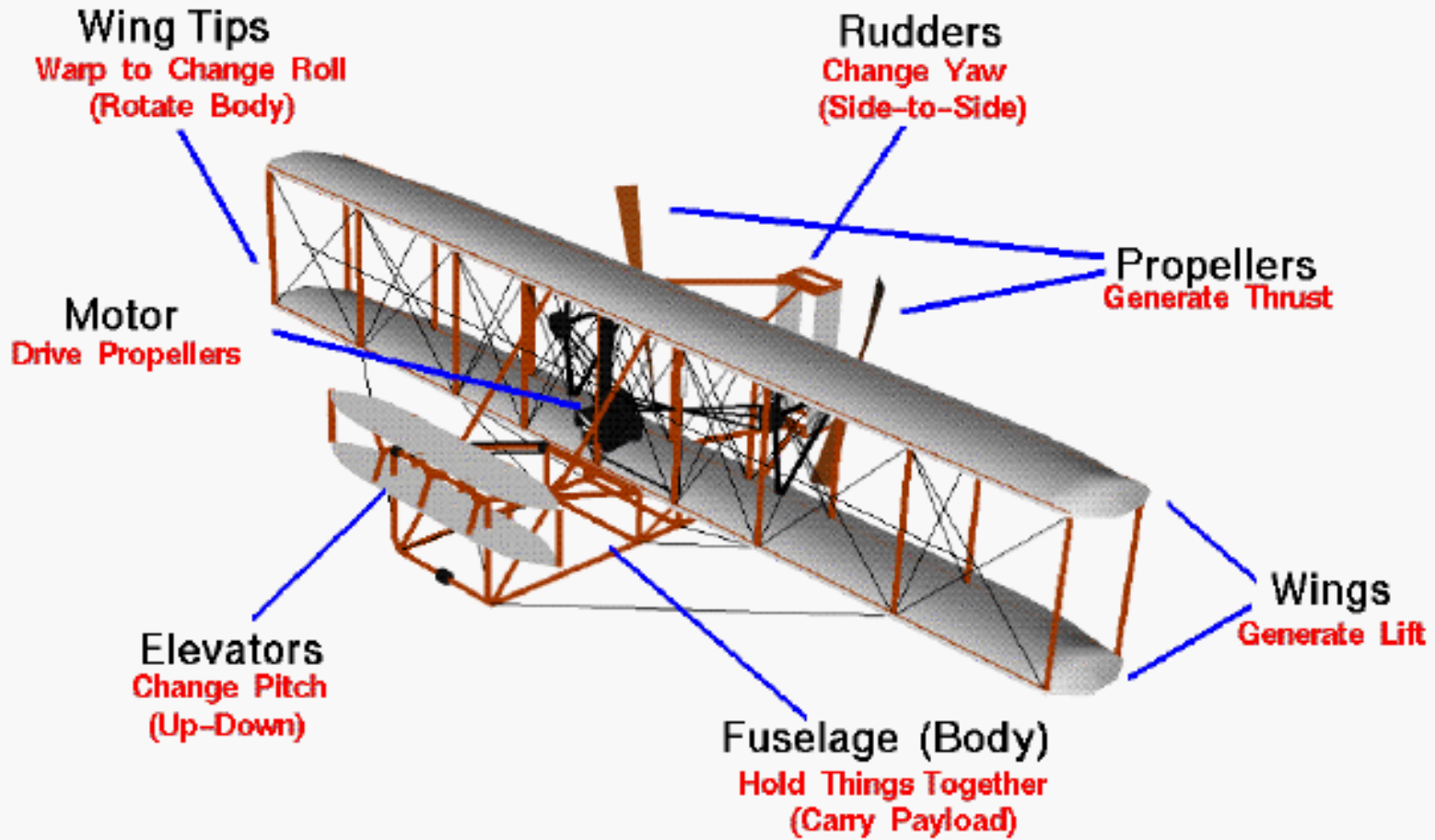



Dror Artzi

שליטה בעילרוד

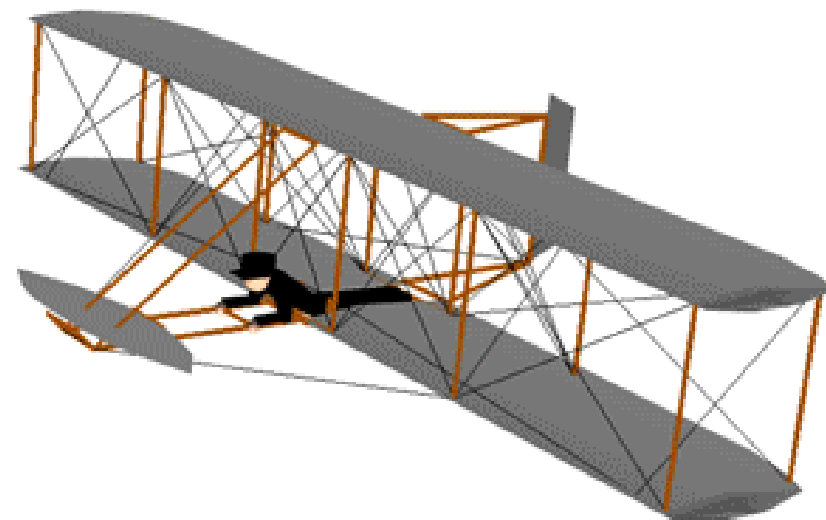

שליטה בסבסוב

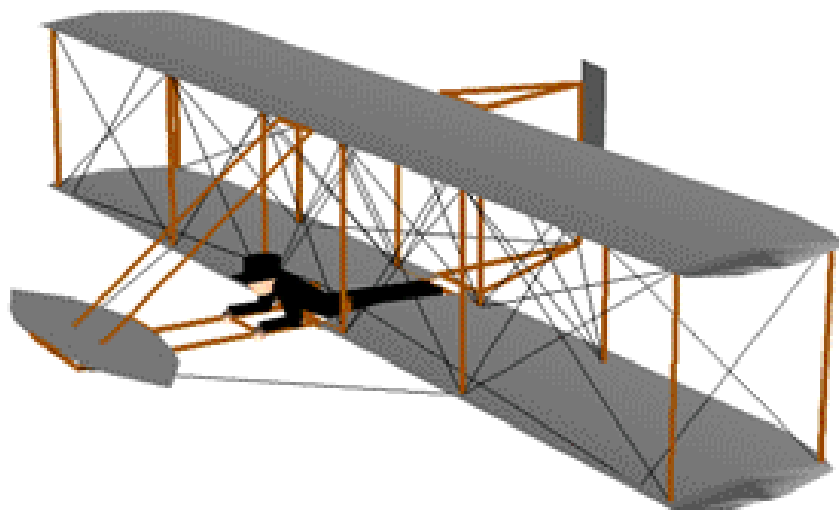



Dror Artzi

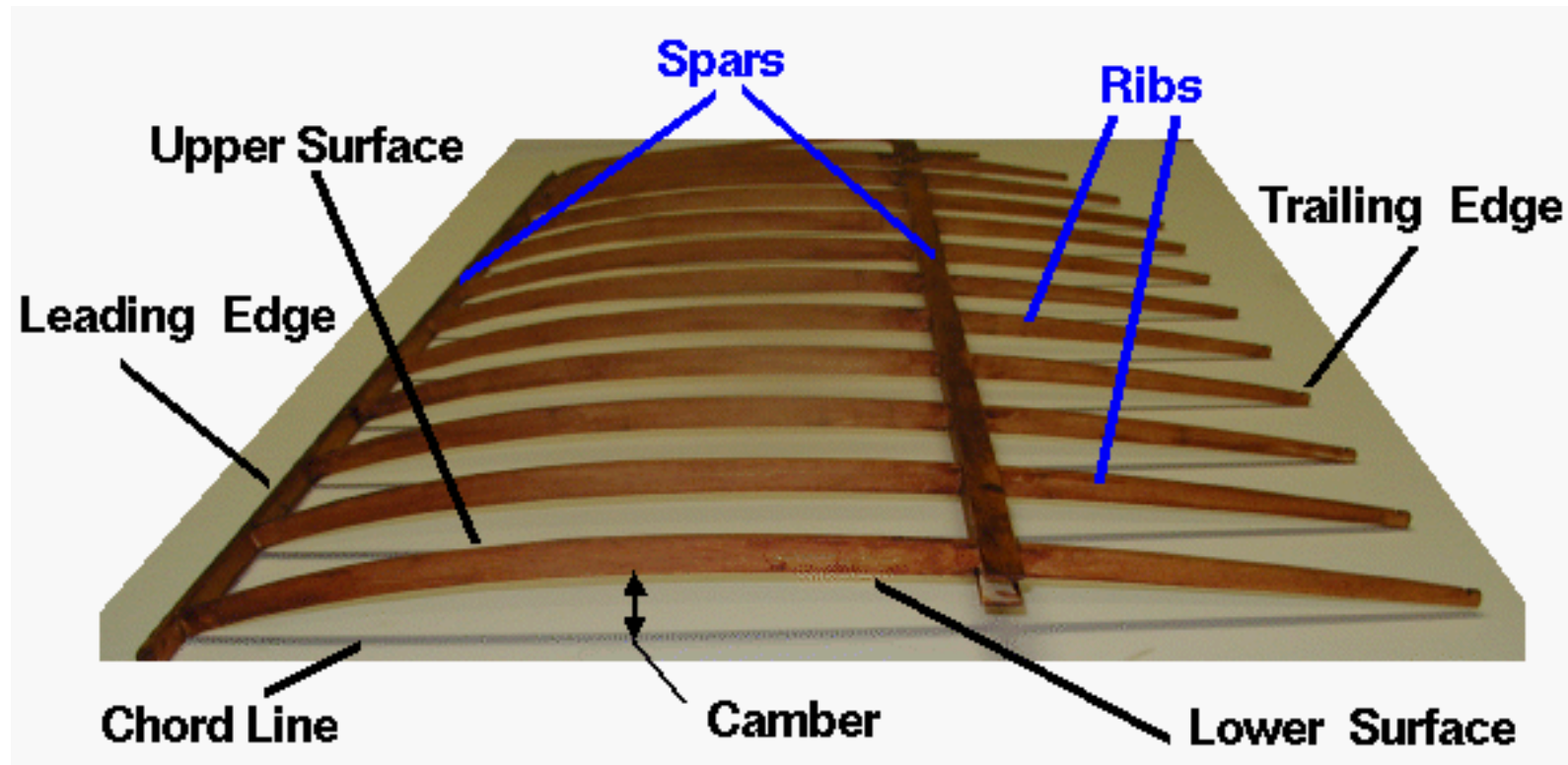



Dror Artzi



# ***Elevators***

*Wright 1903 Flyer*

Glenn  
Research  
Center

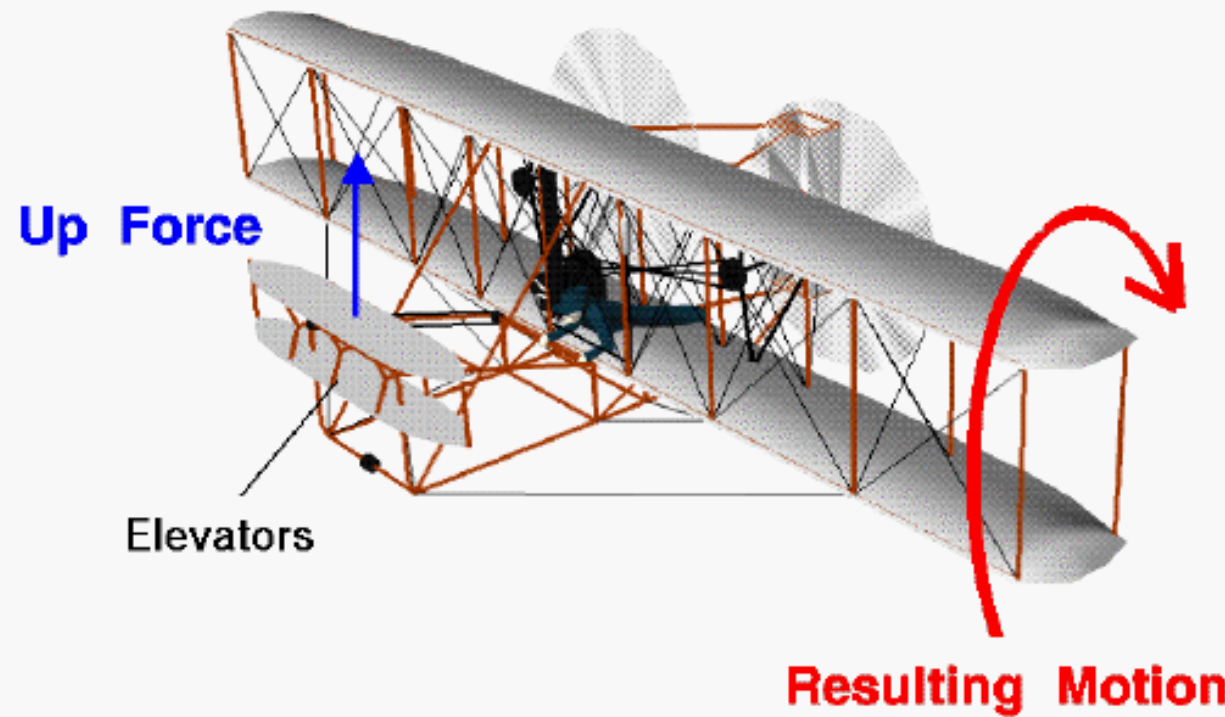

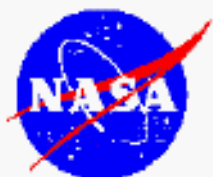

# Rudder - Yaw

*Wright 1903 Flyer*

Glenn  
Research  
Center

## Resulting Motion

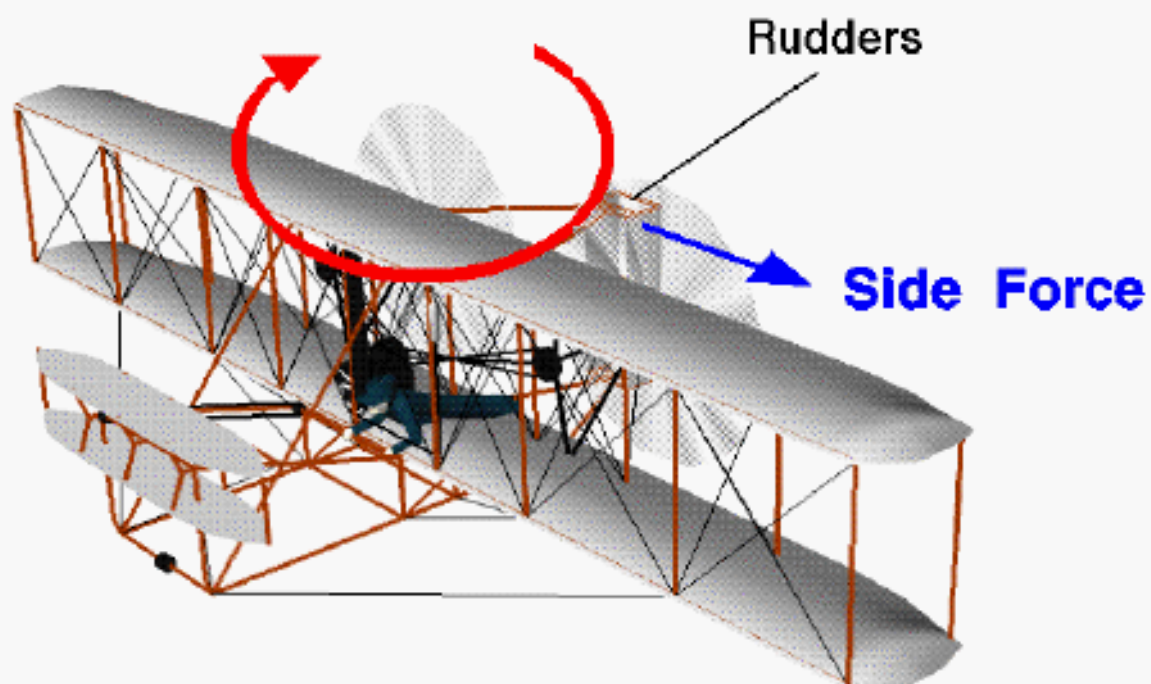



## אין מנוע?

In December of 1902, the Wright brothers sent out letters of inquiry to 10 different manufacturers of gasoline engines, asking for an engine that could develop **8-9 horsepower**, weigh no more than **180 pounds**, and be free from vibration. All 10 replied they did not make such an engine. Disappointed, Wilbur sought out Charlie Taylor, a machinist they had hired to run their bicycle shop

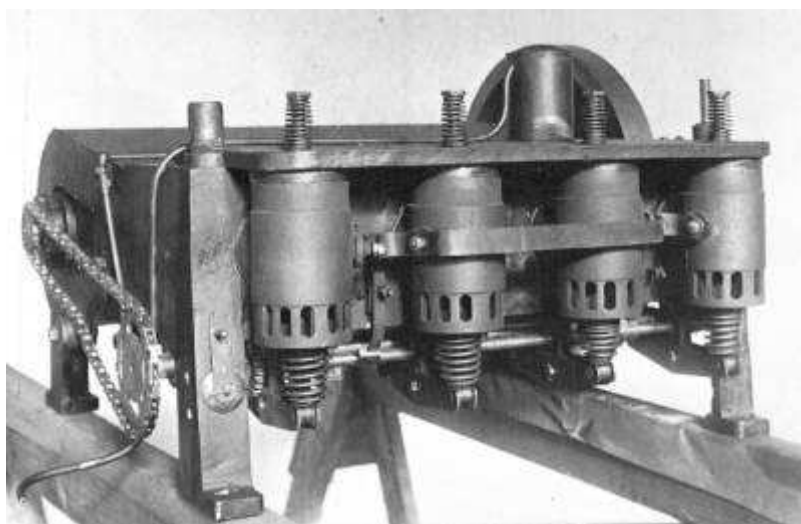

*horizontal 4-cylinder engine.*

אז מפתחים ובונים



Dror Artzi

ומתקינים במטוס עם חיבור "שרשרת אופניים" להנעת המדחפים

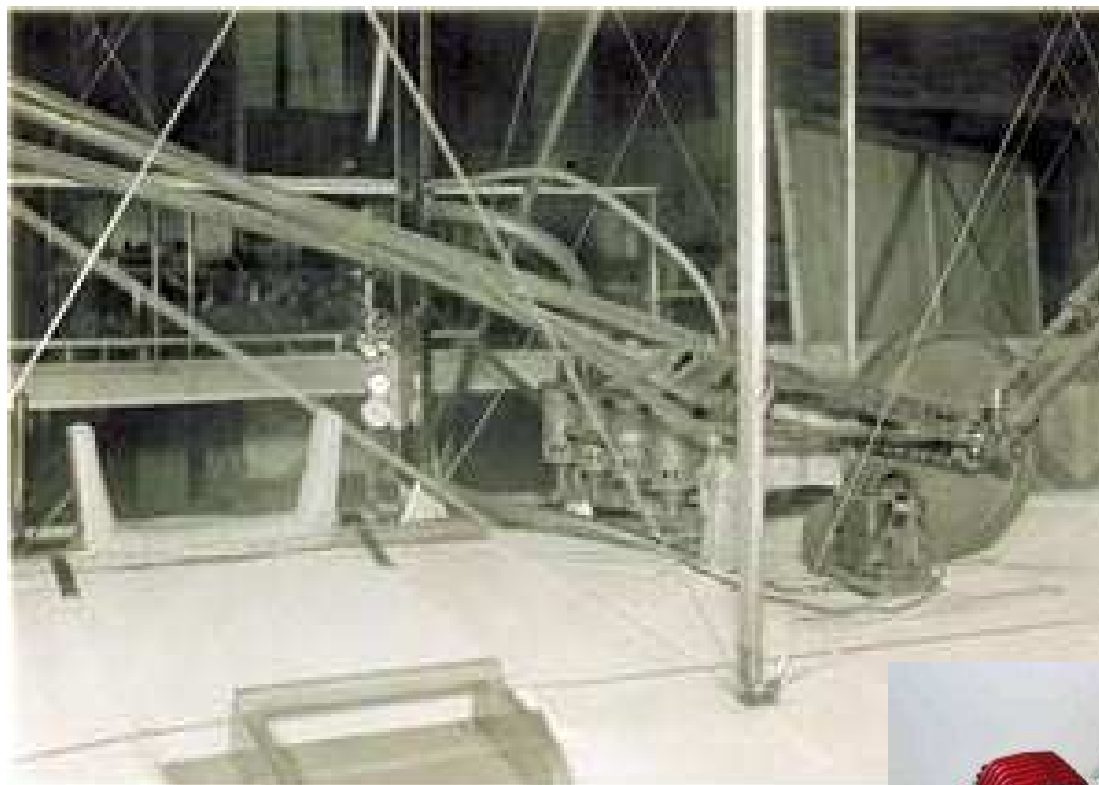

10 כ"ס  
3 ק"ג



Dror Artzi

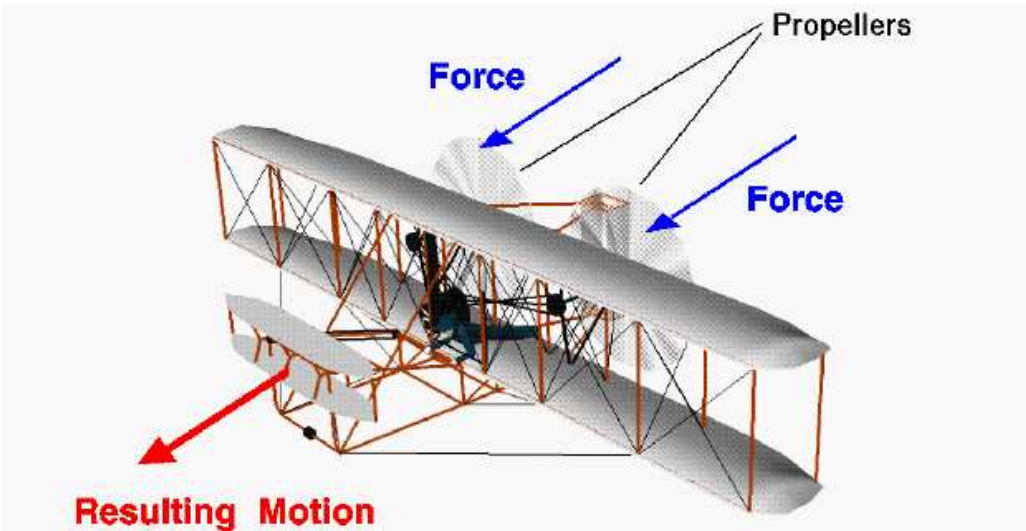
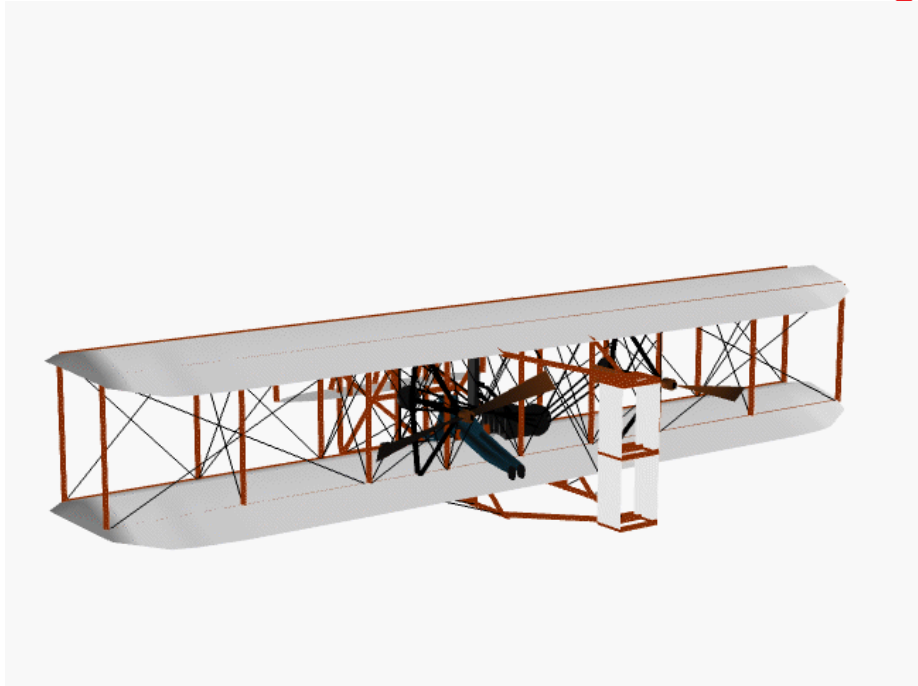



Dror Artzi

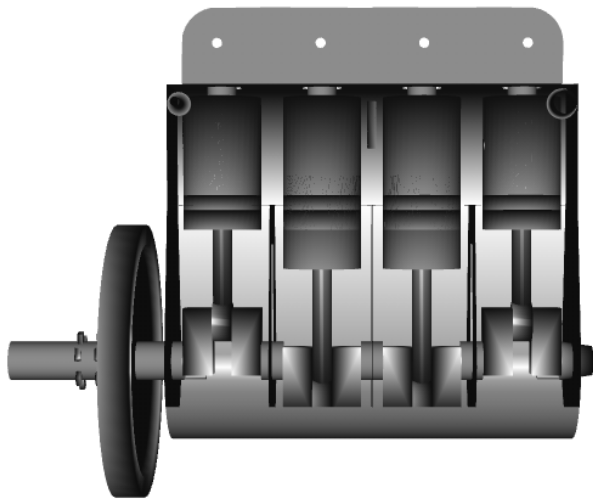
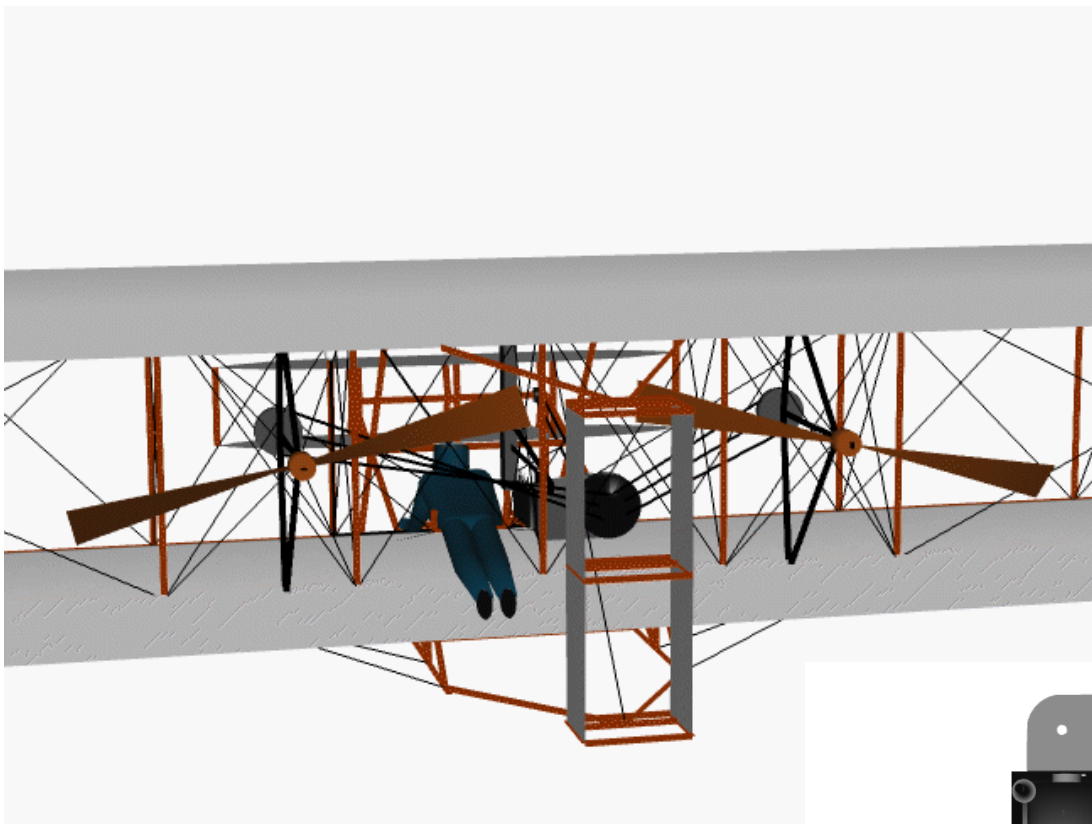



# Wright 1903 Engine Parts

Glenn Research Center

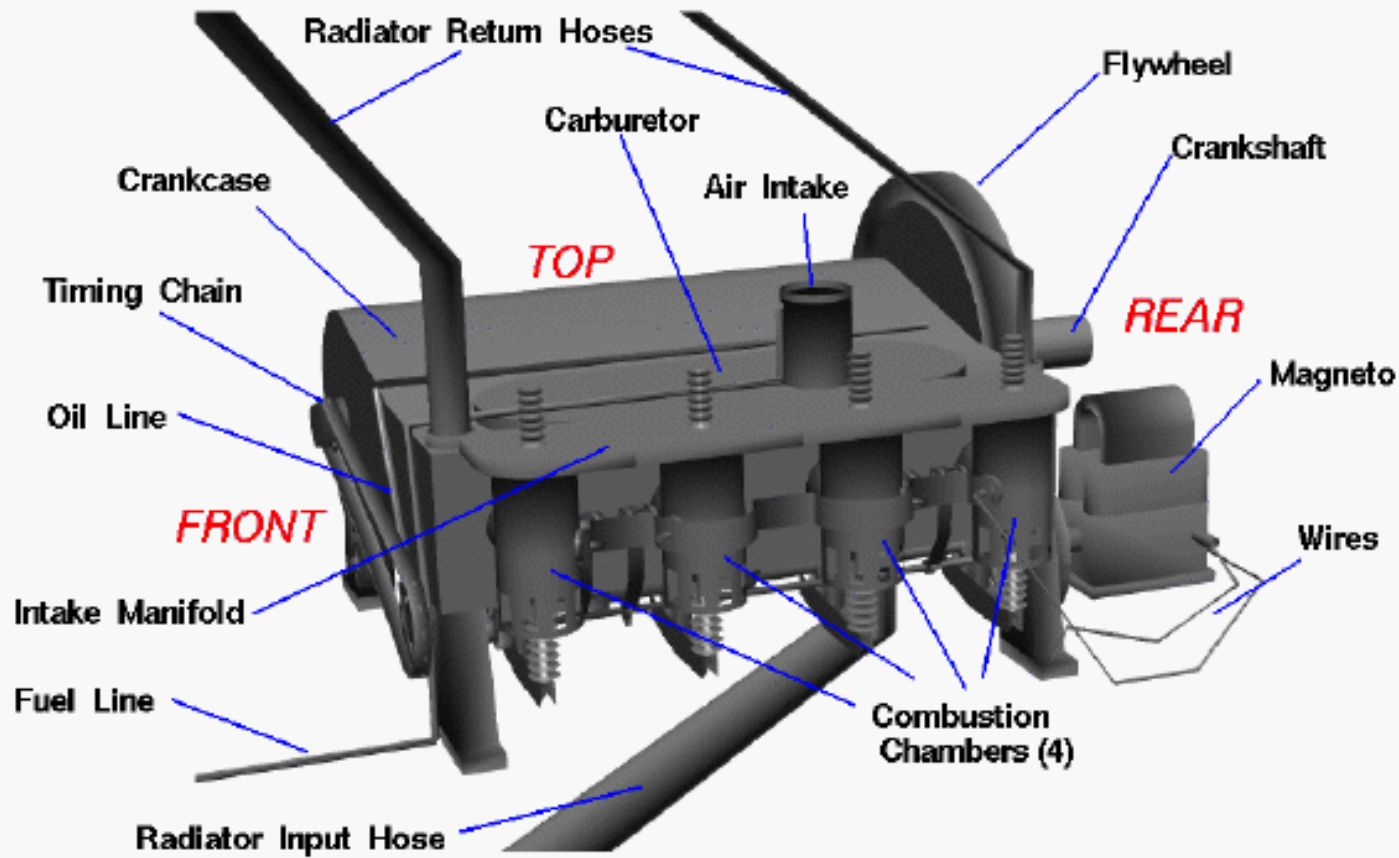



Dror Artzi

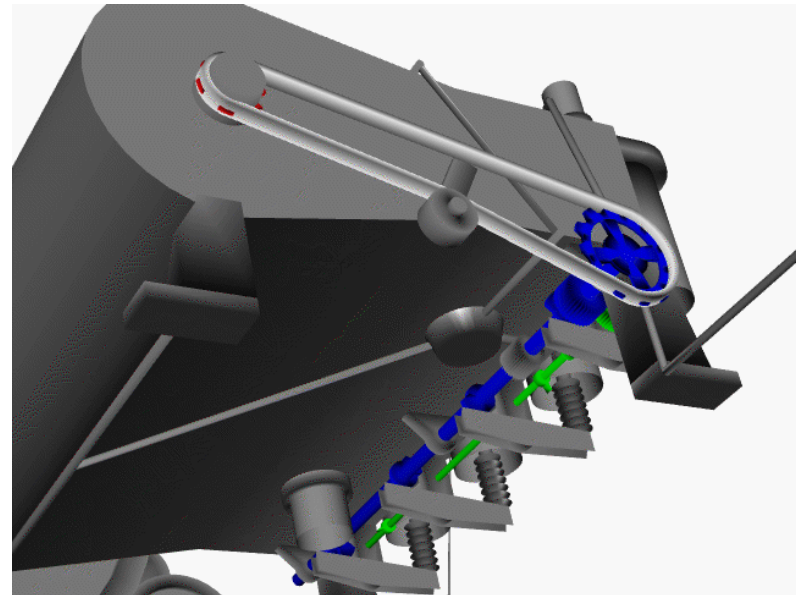
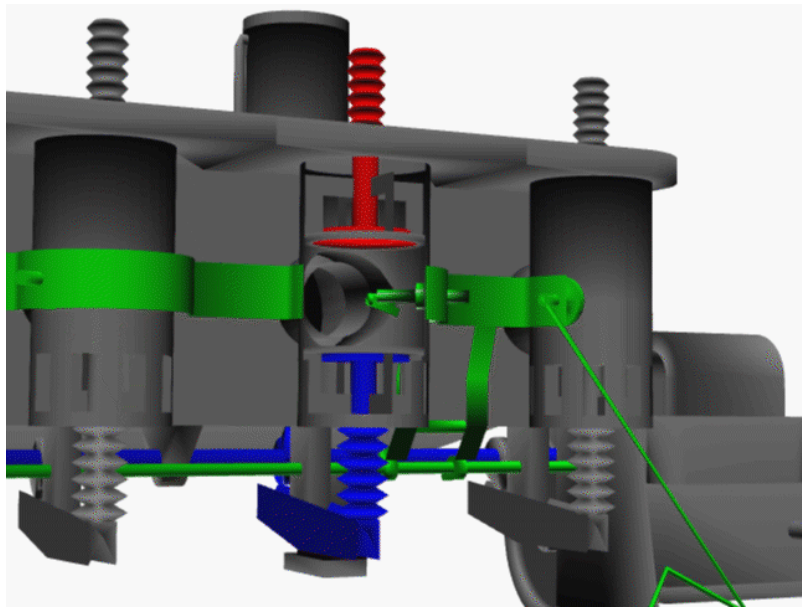
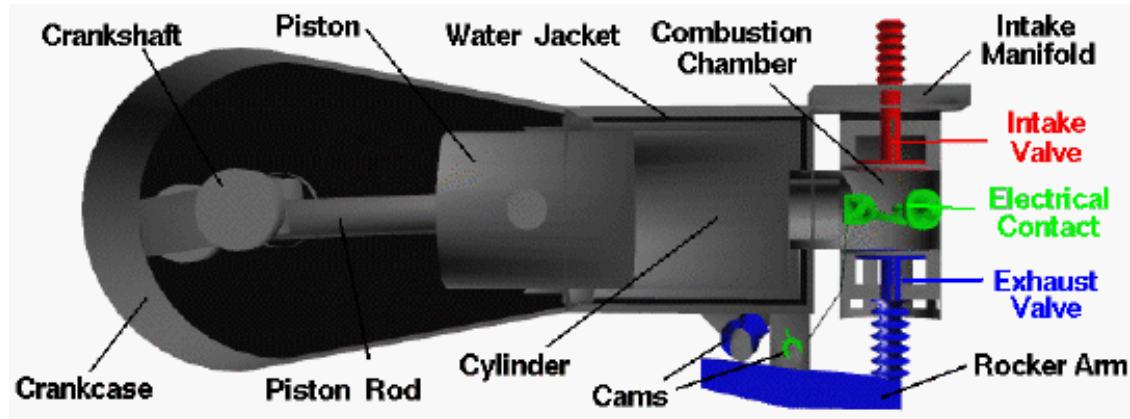



Dror Artzi

## The Wrights' Propeller Blade Had A Completely New Pitch

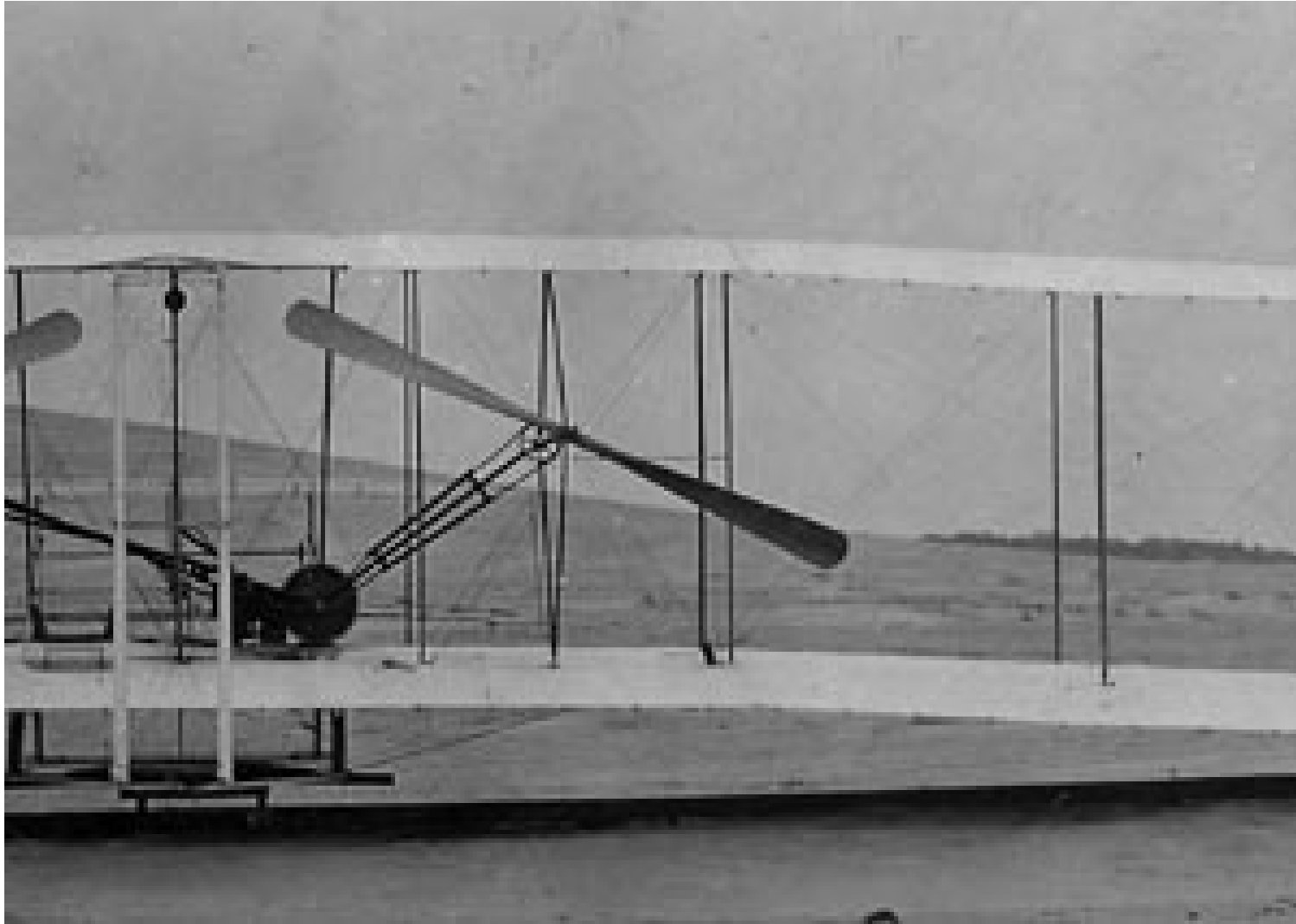





Dror Artzi

# fuel system

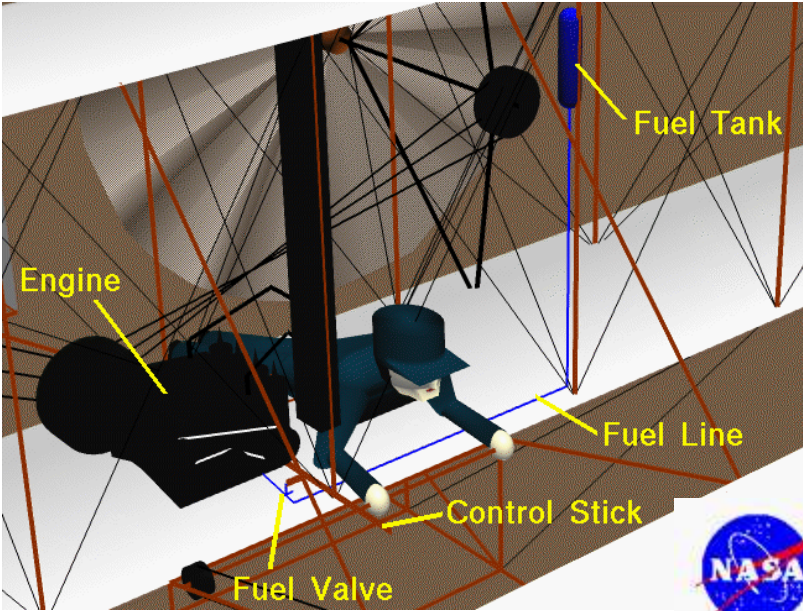

## Engine Fuel System Wright 1903 Engine

Glenn  
Research  
Center

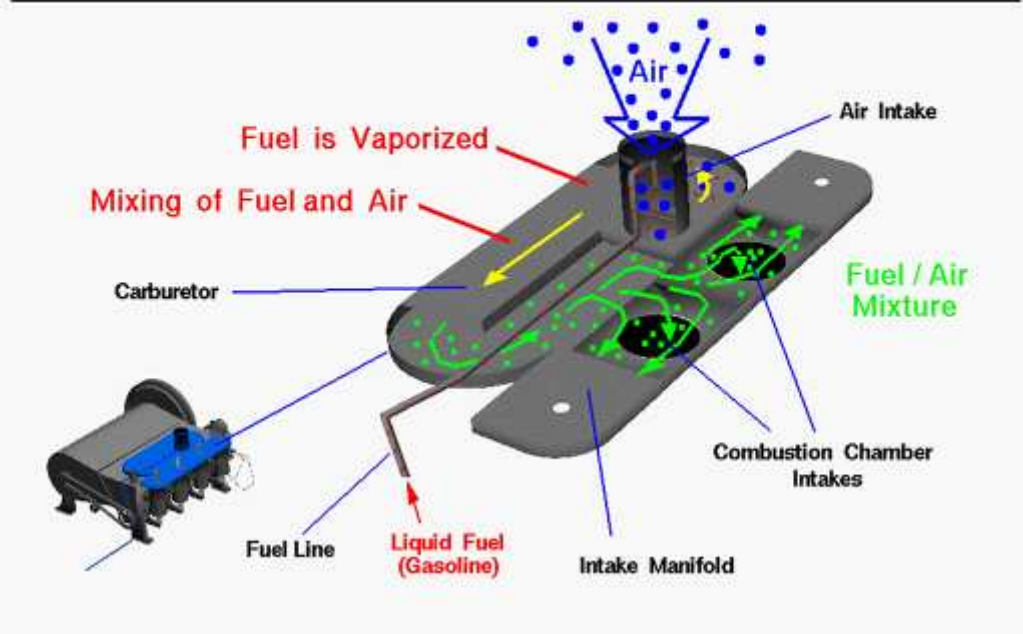



Dror Artzi

1903

Final Construction of the "Flyer" Took Place At Kitty Hawk

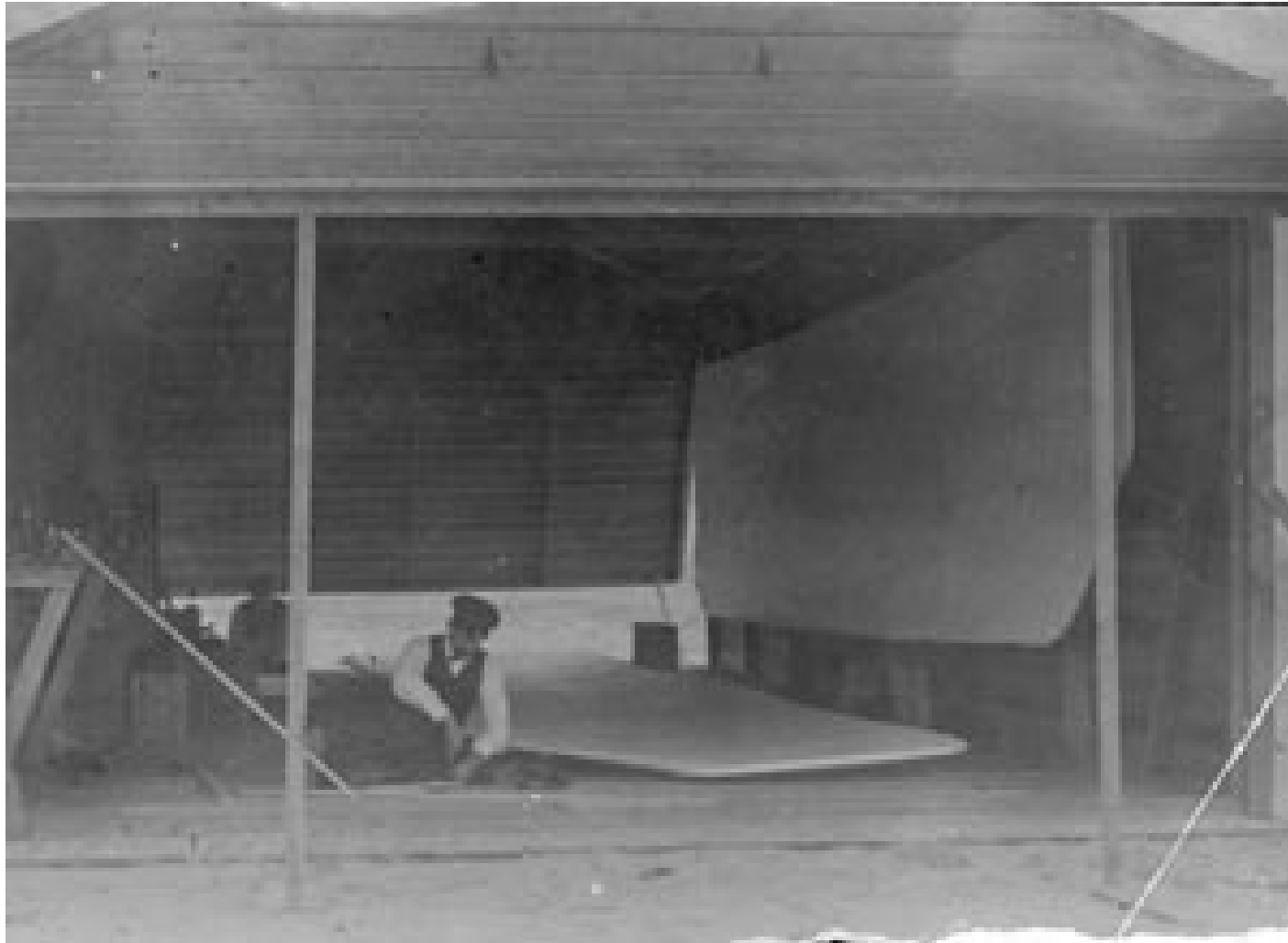



Dror Artzi

## The Completed "Flyer" Beside the Camp Sheds.





Dror Artzi

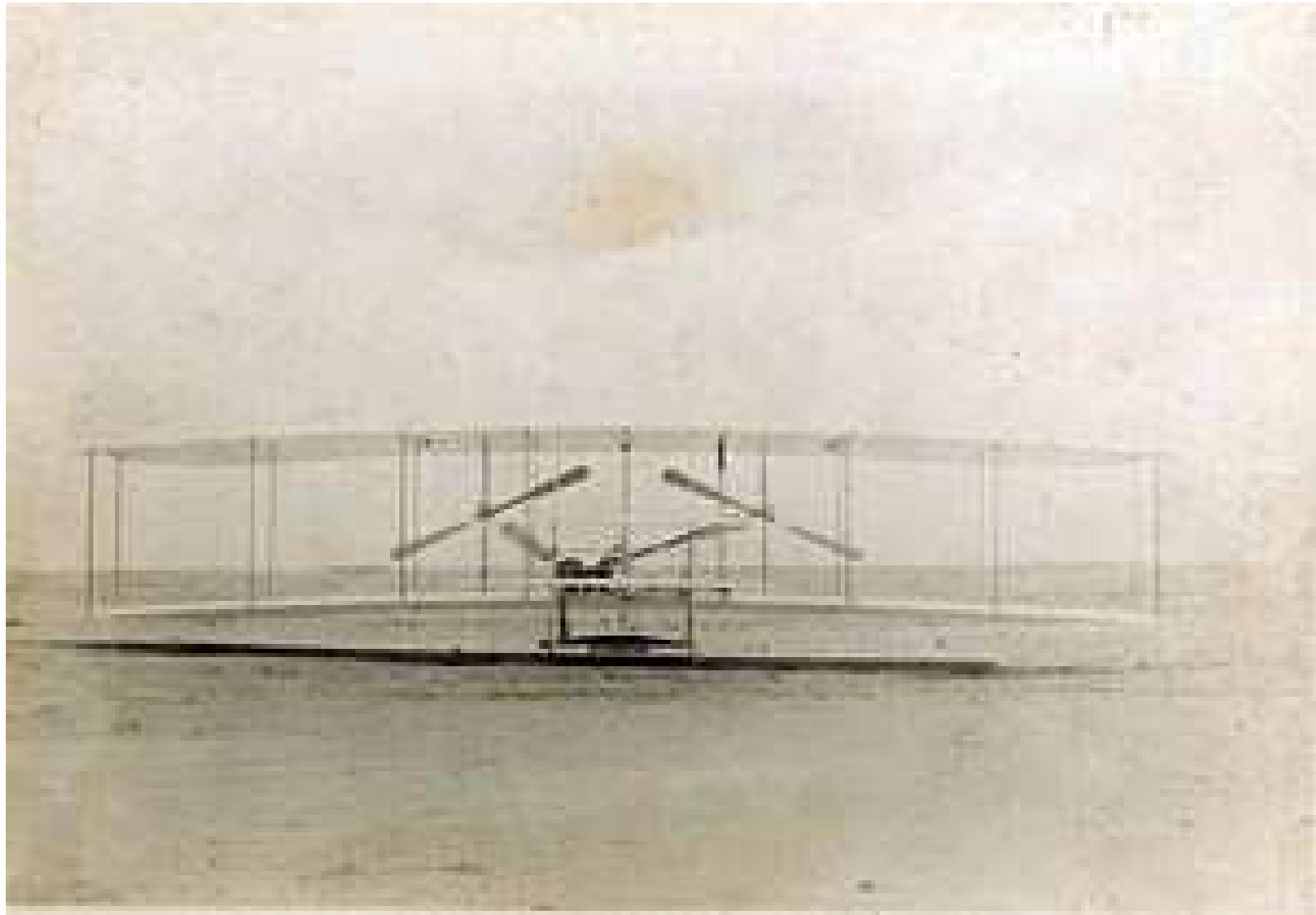



Dror Artzi

Wilbur's first attempt ended in a jarring crash

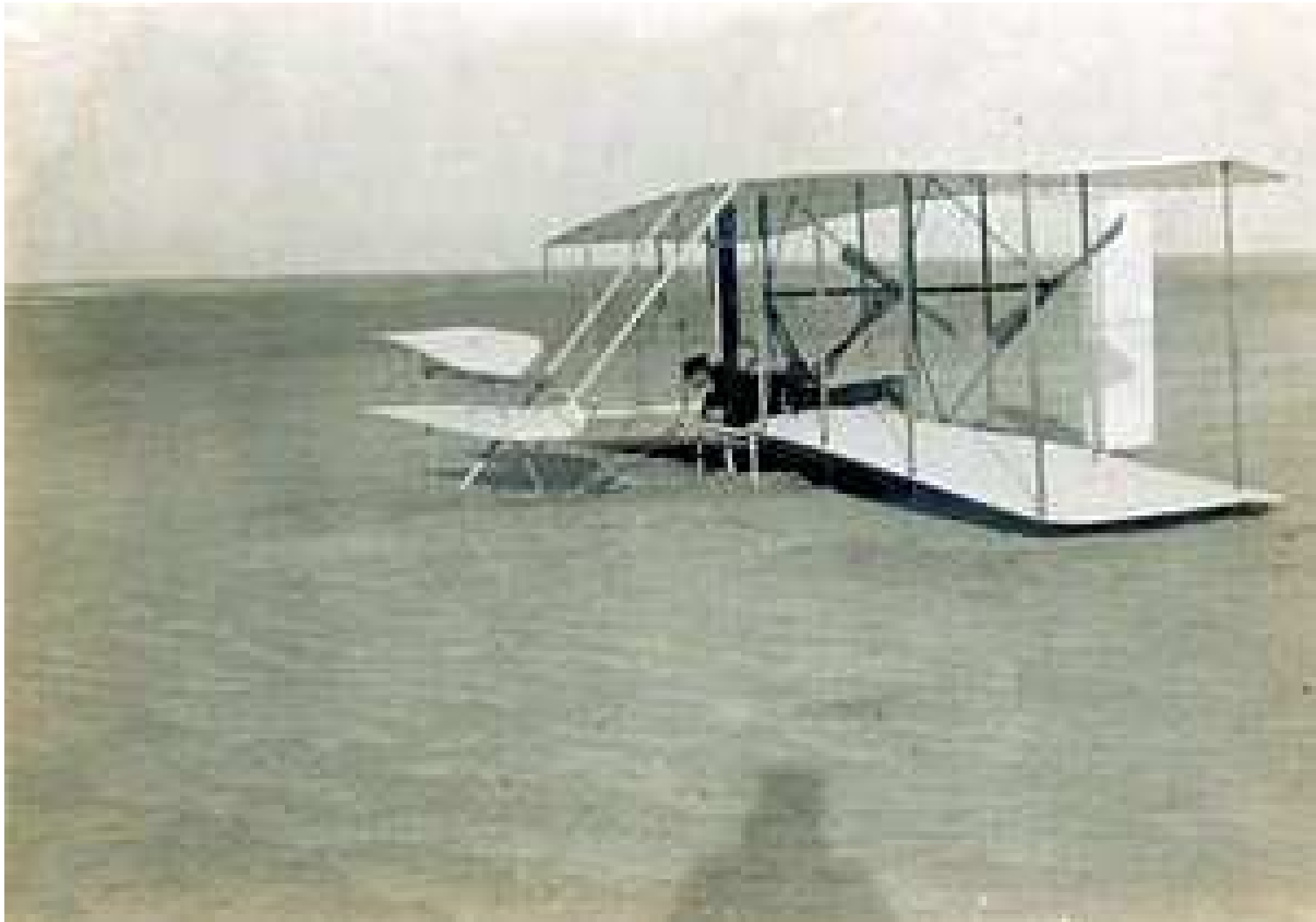



Dror Artzi

## Getting ready to fly in Kitty Hawk on December 14, 1903.





Dror Artzi

*December 17 1903 At 10:35*

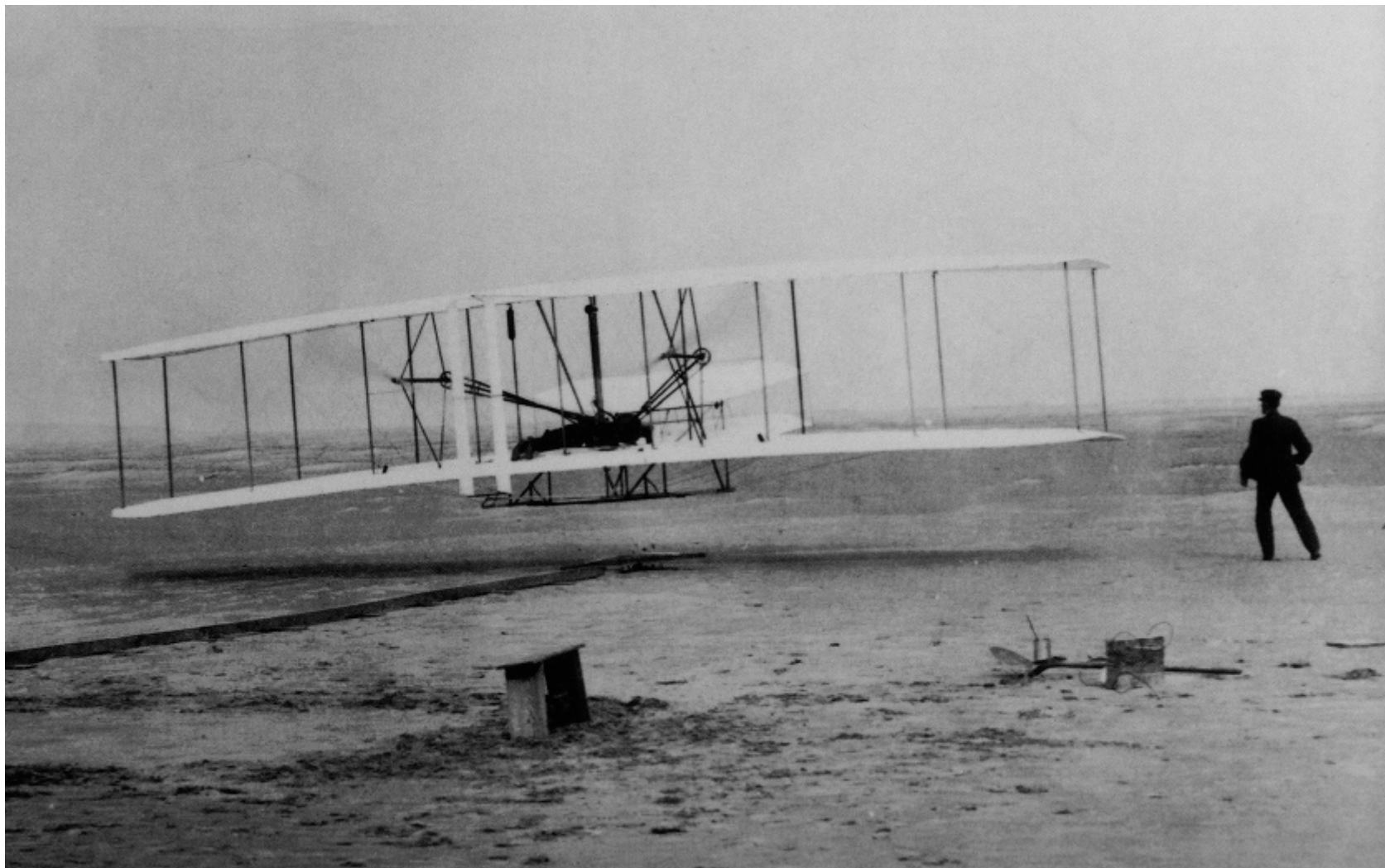



Dror Artzi

After the flights, the Wrights sent home this telegram to their father confirming their success.

It mistakenly states the longest flight as 57 seconds and misspells Orville's name.

Form No. 100.

**THE WESTERN UNION TELEGRAPH COMPANY.**  
INCORPORATED  
23,000 OFFICES IN AMERICA. CABLE SERVICE TO ALL THE WORLD.

This Company TRANSMITS and DELIVERS messages only in accordance with the following conditions, which have been accepted in by the sender of the following message. It cannot be granted against any person who is responsible for the sending of a message, and the Company will not be held liable for errors or delays in transmission or delivery of telegraphed messages, beyond the amount of bills paid thereon, nor in any case where the liability is not presented in writing within sixty days after the message is filed with the Company for transmission.  
This is an UNREPEATED MESSAGE, and is delivered by request of the sender, under the conditions named above.  
ROBERT D. CLOWRY, President and General Manager.

---

**RECEIVED at** 170

176 G KA OS 33 Paid. Via Norfolk Va

Kitty Hawk N C Dec 17

Bishop W Wright

7 Hawthorne St

Success four flights thursay morning all against twenty one mile  
wind started from Level with engine power alone average speed  
through air thirty one miles longest 57 seconds inform Press  
home ~~boys~~ Christmas. Orville Wright 525P



## 4 טיסות ב 17 לדצמבר

- טיסה ראשונה 10:40 12 שניות 120 רגל (אורביל)
- טיסה שניה 11:20 13 שניות 195 רגל (ווילבור)
- טיסה שלישית 11:40 15 שניות 200 רגל (אורביל)
- טיסה רביעית 12:00 59 שניות 852 רגל (ווילבור)



# Attempts at Flight 1890 - 1909

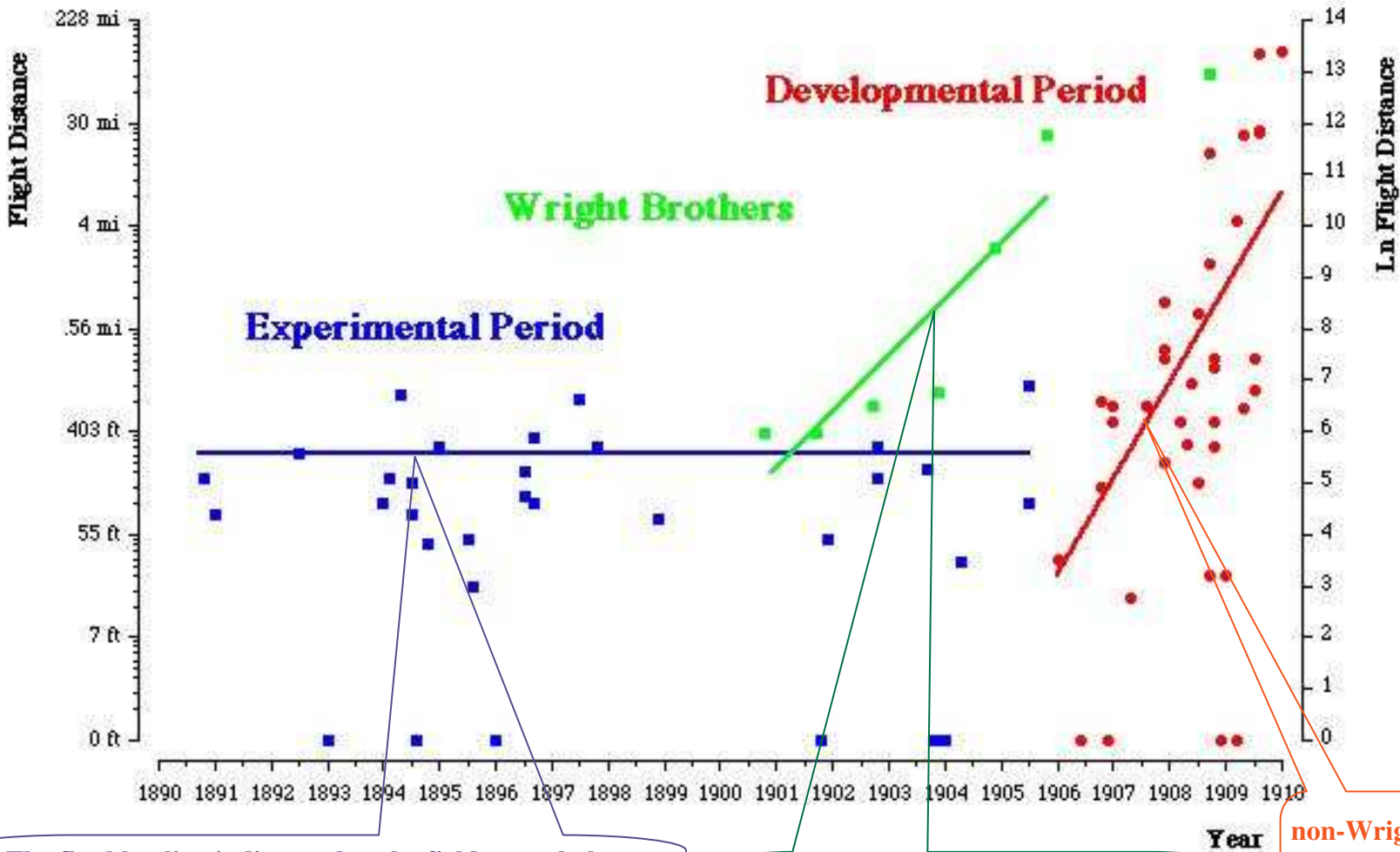

The flat blue line indicates that the field as a whole was making NO sustained progress through the end of 1905.

The positive slope of the Wright brothers indicates a steady progression in the ability of their heavier-than-air craft.

non-Wright craft made from 1906 to 1909.



Dror Artzi

# UNITED STATES PATENT OFFICE.

ORVILLE WRIGHT AND WILBUR WRIGHT, OF DAYTON, OHIO.  
FLYING-MACHINE.

No 821,393.

Specification of  
Letters Patent.

Patented May 22,  
1906.

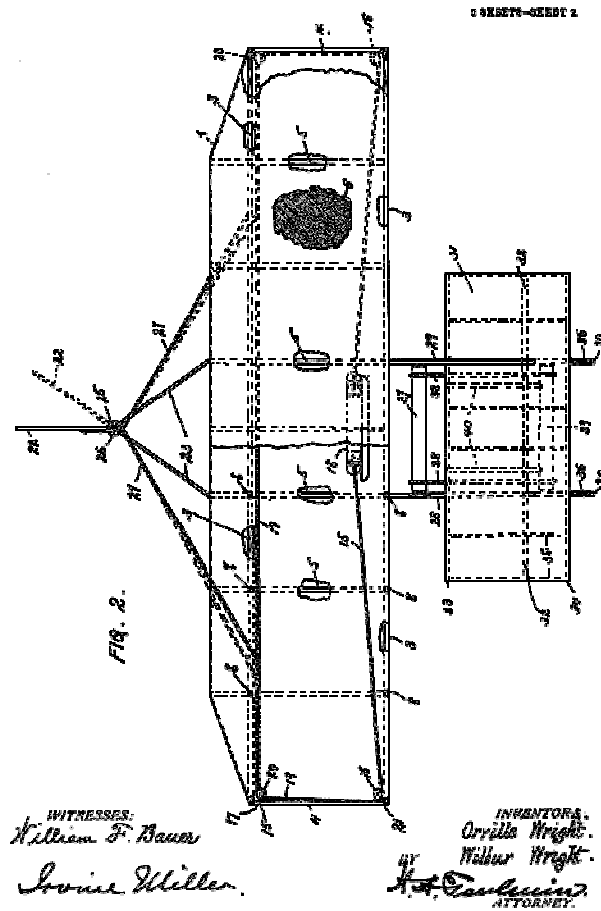
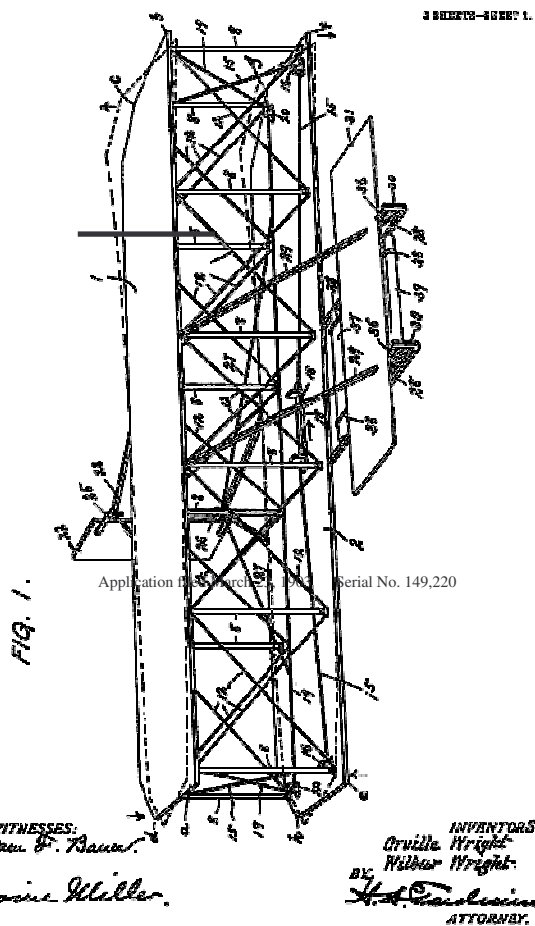



Dror Artzi

3 SHEETS-SHEET 3.

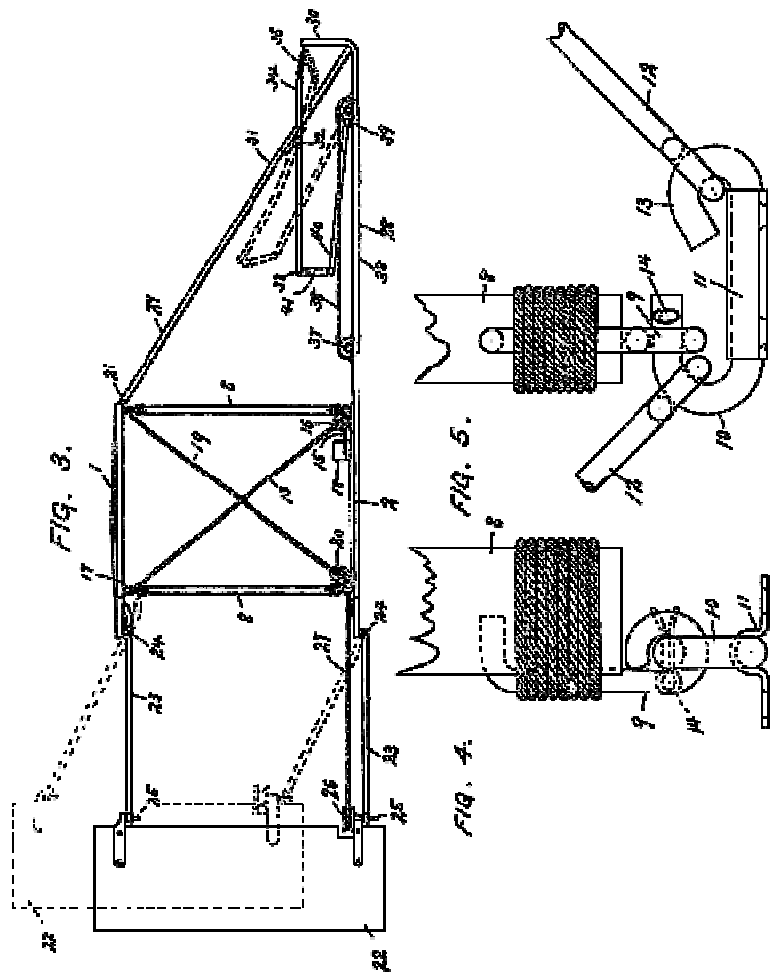

WITNESSES:  
 William F. Bauer.  
 Irvine Miller.

INVENTORS.  
 Orville Wright.  
 Wilbur Wright.  
 BY  
 H. A. Coulter,  
 ATTORNEY.



Dror Artzi

# והיום בקיטי הוק





Dror Artzi

*Orville (left) and Wilbur Wilbur (right)*

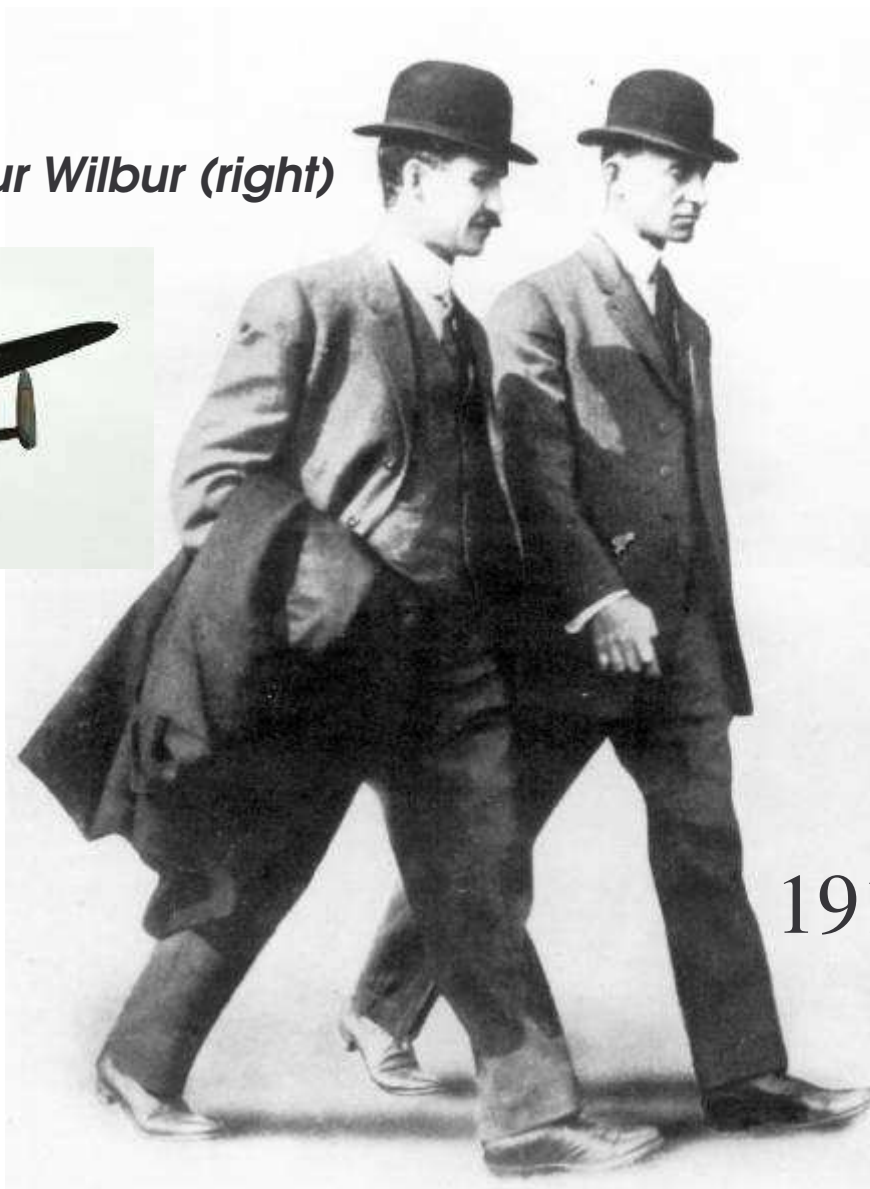

*Orville*  
1948, Jan. 30  
Age 77

*Wilbur*  
1912 May 30  
Age 45



Dror Artzi

Official reproduction Wright Flyer I unsuccessfully attempting to take off at Kitty Hawk on 17 December 2003 in waterlogged conditions





Dror Artzi

שאלות ?

